

Hi-Techno Pump

IX-B-S6



High output, high precision, high controllability

High efficiency brushless motor driven diaphragm type metering pumps

A new stainless steel type was added to the diaphragm type metering pump IX-B series which adopted a brushless motor with high efficiency and high controllability.

Unique Motor Design

The IX-B pumps use brushless DC (BLDC) motors to control the pump stroke speed. Many similar metering pumps use a stepper-motor based design, however the efficiency of the BLDC motor provides a higher power output in a smaller package and allows the IX-B pumps to achieve 45L/H discharge flowrates.

Flexible Installation (Patent Pending)

The IX-B Pumps have been designed to be installed into various locations. The control unit can easily be repositioned by customers on-site. ①

LED Status Bar

A large LED status bar provides simple visual indication of operating conditions at a glance. It is easily visible to see the pump status at a distance or in dark locations. ②

① : Upward 4 directions
(every 90 degrees)

② : It's an image of lighting.

Note: IX-B-S6 can not be wall mounted installation.



Construction

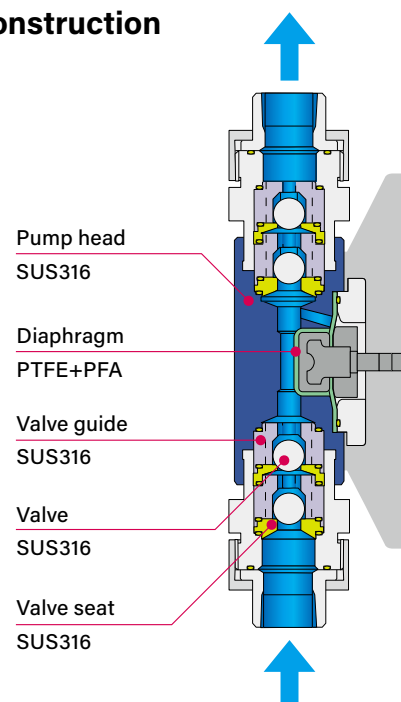

Identification

IX	-	B	007	S6	R	-	E	□□
①		②	③	④	⑤		⑥	

- ① Drive unit
B
- ② Pump size
007.....7.5L/H
015.....15L/H
030.....30L/H
045.....45L/H
- ③ Liquid-end material
S6
Please refer to above figure.
- ④ Connection
R.....Thread (Rc)
N.....Thread (FNPT)
FJ.....Flange (JIS)
FD.....Flange (DIN)
FA.....Flange (ANSI)
- ⑤ Type of power code
E.....Europe
U.....U.S.A. 115V
U2.....U.S.A. 230V
A.....Australia
J.....Asia
- ⑥ Special arrangement code

Dimensions (mm)

Moel		A	B	C	D	E	F
IX-B (007/015) S6	R	161	82	260	275	94.5	29
	N						
	FJ	247	39	260	275	94.5	29
	FD FA						
IX-B (030/045) S6	R	183	72	262	278	97	28
	N						
	FJ	269	29	262	278	97	28
	FD FA						

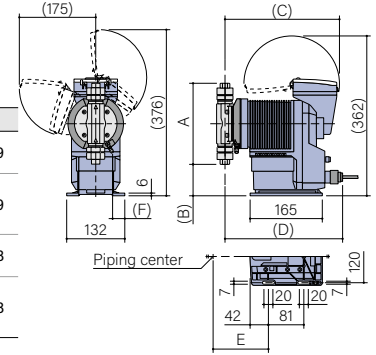

Specifications

Pump

Model	Capacity L/h	Max. Pressure MPa	Power consumption W	Current A	Connection	Mass kg
IX-B007 S6	0.0075 - 7.5 ^{Note}	1.7	17	0.4	Rc3/8	4.5
					3/8 FNPT	
		1.0			JIS 10K 15A	6.0
					DIN PN10 DN15 ANSI 150lb 1/2"	
IX-B015 S6	0.015 - 15 ^{Note}	1.0	17	0.4	Rc3/8	4.5
					3/8 FNPT	
		1.0			JIS 10K 15A	6.0
					DIN PN10 DN15 ANSI 150lb 1/2"	

Note: Discharge flow rate may be less than set value.

Model	Capacity L/h	Max. Pressure MPa	Power consumption W	Current A	Connection	Mass kg	
IX-B030 S6	0.030 - 30 ^{Note}	0.6	19	0.5	Rc3/8	5.0	
					3/8 FNPT		
					1.0	JIS 10K 15A	6.5
						DIN PN10 DN15 ANSI 150lb 1/2"	
IX-B045 S6	0.045 - 45 ^{Note}	0.4	19	0.5	Rc3/8	5.0	
					3/8 FNPT		
					1.0	JIS 10K 15A	6.5
						DIN PN10 DN15 ANSI 150lb 1/2"	

- The above is the value at rated voltage, ambient temperature and clear water.
- Liquid temperature range: 0 - 80 °C (No viscosity change, Non freezing, No slurry)
0 - 50 °C (32 - 122 °F) for U.S.A. type

Controller

Operation mode	MAN (Manual)	Use the UP (↑) and DOWN (↓) keys to set a flow rate.	
	EXT	Analog fixed operation	4-20, 0-20, 20-4, 20-0mA (Proportional to the discharge rate)
		Analog variable operation	Programmable 2-point setting (Input signal DC 0-20 mA, proportional to the discharge rate)
		Pulse control ^{Note1}	0.000625mL/PLS - 15.000000mL/PLS (IX-B007), 0.001250mL/PLS - 30.000000mL/PLS (IX-B015)
		Batch control ^{Note1}	0.002500mL/PLS - 60.000000mL/PLS (IX-B030), 0.003750mL/PLS - 90.000000mL/PLS (IX-B045)
			0.625mL/PLS - 15.000L/PLS (IX-B007), 1.250mL/PLS - 30.000L/PLS (IX-B015)
		Interval batch control ^{Note1}	2.500mL/PLS - 60.000L/PLS (IX-B030), 3.750mL/PLS - 90.000L/PLS (IX-B045)
Profibus control ^{Note7}	Day: 0 - 9, Hour: 0 - 23, Minute: 1 - 59 0.625mL/PLS - 15.000L/PLS (IX-B007), 1.250mL/PLS - 30.000L/PLS (IX-B015) 2.500mL/PLS - 60.000L/PLS (IX-B030), 3.750mL/PLS - 90.000L/PLS (IX-B045) Communication protocol: Profibus-DP-compliant international standard: EN50170 (IEC61158)		
Monitors	LCD	16 digits × 2 lines, backlit character LCD	
	LED	White: When the pump is stopped etc., Green: During pump operation etc., Orange: When entering Pre-Stop etc., Red: When alarm such as abnormal pressure detection etc.	
Operation	Keypads	(⊙)Start/Stop, MENU, ESC, (↵)Enter, (↑)Up, (↓)Down, (←)Left and (→)Right keys	
Control function	STOP	Operation stops with input contact ^{Note2}	
	PRIME	Max spm operation by pressing the (↑)UP and (↓)DOWN keys	
	Keylock	Password setting to lock and release operation keys	
	Interlock	Operation stops with input contact ^{Note2}	
	AUX	Pump operates at the set discharge rate with input contact.	
	Maximum discharge rate	Arbitrarily set the upper discharge limit in each operation mode.	
	Buffer memory function	Store the number of pulses entered in batch operation.	
Input	Analog input value display	Display the analog input value.	
	STOP/Pre-Stop, AUX, Interlock	Non-voltage contact or open collector ^{Note3}	
	Analogue Pulse	0 - 20mADC (Internal resistance is 200Ω.) Non-voltage contact or open collector Max pulse frequency is 100Hz. (Pulse ON: 5 msec or more)	
Output	Alarm1 (OUT1)	Non-voltage contact (mechanical relay): AC 250 V, 3 A (resistive load) Each output item is selected by Enable/Disable. (Initial value: Leak Detection only Enable) Stop/Pre-Stop/Interlock/Leak Detection/Motor Overload/Batch Complete ^{Note4} /Drive Error	
	Alarm2 (OUT2)	Non-voltage contact (photo MOS relay): AC/DC 24 V, 0.1 A (resistive load) Each output item is selected by Enable/Disable. (Initial value: Interlock only Enable) Stop/Pre-Stop/Interlock/Leak Detection/Motor Overload/Batch Complete ^{Note4} /Drive Error/Volume Prop. PLS ^{Note5}	
	External power supply	DC12V 30mA or less	
	Current	DC 0-20 mA, Two-point setting (allowable load resistance: 300 Ω)	
Power voltage ^{Note6}		100-240VAC 50/60Hz	

Note1: The minimum settings for pulse operation, batch operation, and interval batch operation are the flow rates per stroke corrected by calibration. Also, the change rate of the setting value per pulse is the flow rates per stroke corrected by calibration.

Note2: Pump operation or pump stop can be selected at contact input.

Note3: The maximum voltage and current applied to the contact are 12 V and 5 mA. If you use a contact such as a relay, the minimum applicable load must be 5 mA or less.

Note4: When Batch Complete (batch operation complete output) is set to Enable, the other functions will be set to Disable.

Note5: When Volume Prop. PLS output is set to Enable, the other functions will be set to Disable.

Note6: Do not apply voltage out of the specified range. Doing so may cause malfunction or failure. The allowable voltage supply range is 90-264VAC only.

Note7: When conducting Profibus bus operation, a separate Profibus Conversion BOX (option) is required.

IWAKI CO., LTD. 6-6 Kanda-Sudacho 2-chome Chiyoda-ku Tokyo 101-8558 Japan TEL : (81)3 3254 2935 FAX : 3 3252 8892 IWAKI has global net work. Please find your distributor location at www.iwakipumps.jp

European office : IWAKI Europe GmbH Germany : IWAKI Europe GmbH Holland : IWAKI Europe GmbH (Netherlands Branch) Italy : IWAKI Europe GmbH (Italy Branch) Spain : IWAKI Europe GmbH (Spain Branch) Belgium : IWAKI Belgium N.V. Denmark : IWAKI Nordic A/S Finland : IWAKI Suomi Oy France : IWAKI France S.A. Norway : IWAKI Norge AS Sweden : IWAKI Sverige AB U.K. : IWAKI Pumps (UK) Ltd.	TEL: (49)2154 9254 0 FAX: 2154 9254 48 TEL: (49)2154 9254 50 FAX: 2154 9254 55 TEL: (31)74 2420011 FAX: (49)2154 925448 TEL: (39)0444 371115 FAX: 0444 335350 TEL: (34)93 37 70 198 FAX: 93 47 40 991 TEL: (32)13 67 02 00 FAX: 13 67 20 30 TEL: (45)48 24 2345 FAX: 48 24 2346 TEL: (358)9 2745810 FAX: 9 2742715 TEL: (33)1 69 63 33 70 FAX: 1 64 49 92 73 TEL: (47)23 38 49 00 FAX: 23 38 49 01 TEL: (46)8 511 72900 FAX: 8 511 72922 TEL: (44)1743 231363 FAX: 1743 366507	U.S.A. : IWAKI America Inc. Argentina : IWAKI America Inc. (Argentina Branch) Brasil : IWAKI Do Brasil Comercio De Bombas Hidraulicas LDA. Singapore : IWAKI Singapore Pte Ltd. Indonesia : IWAKI Singapore (Indonesia Office) Malaysia : IWAKI Sdn. Bhd. Australia : IWAKI Pumps Australia Pty Ltd. Hong Kong : IWAKI Pumps Co., Ltd. China : GFTZ IWAKI Engineering & Trading Co., Ltd. IWAKI Pumps (Shanghai) Co., Ltd. Korea : IWAKI Korea Co., Ltd. Taiwan : IWAKI Pumps Taiwan Co., Ltd. Thailand : IWAKI (Thailand) Co., Ltd.	TEL: (1)508 429 1440 FAX: 508 429 1386 TEL: (54)11 4745 4116 TEL: (55)19 3244 5900 FAX: 19 3244 5900 TEL: (65)6316 2028 FAX: 6316 3221 TEL: (62)21 6906606 FAX: 21 6906612 TEL: (60)3 7803 8807 FAX: 3 7803 4800 TEL: (61)2 9899 2411 FAX: 2 9899 2421 TEL: (852)2607 1168 FAX: 2607 1000 TEL: (86)20 84350603 FAX: 20 84359181 TEL: (86)21 6272 7502 FAX: 21 6272 6929 TEL: (82)2 2630 4800 FAX: 2 2630 4801 TEL: (886)2 8227 6900 FAX: 2 8227 6818 TEL: (66)2 322 2471 FAX: 2 322 2477
--	---	---	--

Caution for safety use: Before use of pump, read instruction manual carefully to use the product correctly. Actual pumps may differ from the photos. Specifications and dimensions are subject to change without prior notice. For further details please contact us.

Legal attention related to export. Our products and/or parts of products fall in the category of goods contained in control list of international regime for export control. Please be reminded that export license could be required when products are exported due to export control regulations of countries.

The posting and copying from this catalogue without permission is not accepted firmly.