

IWAKI
HI-TECHNO
PUMPS

IX-B



High output, high precision, high controllability

High efficiency brushless motor driven diaphragm type metering pumps

Hi-Techno Pump

IX-B

Iwaki Hi-Techno Pump IX-B series is a brushless DC motor driven diaphragm type metering pump. The flow control range covers a wide range from 7.5 mL / h to 45 L / h, and various automatic control is also possible. Utility has also been enhanced, including support for highly flexible installation methods and various connection methods.

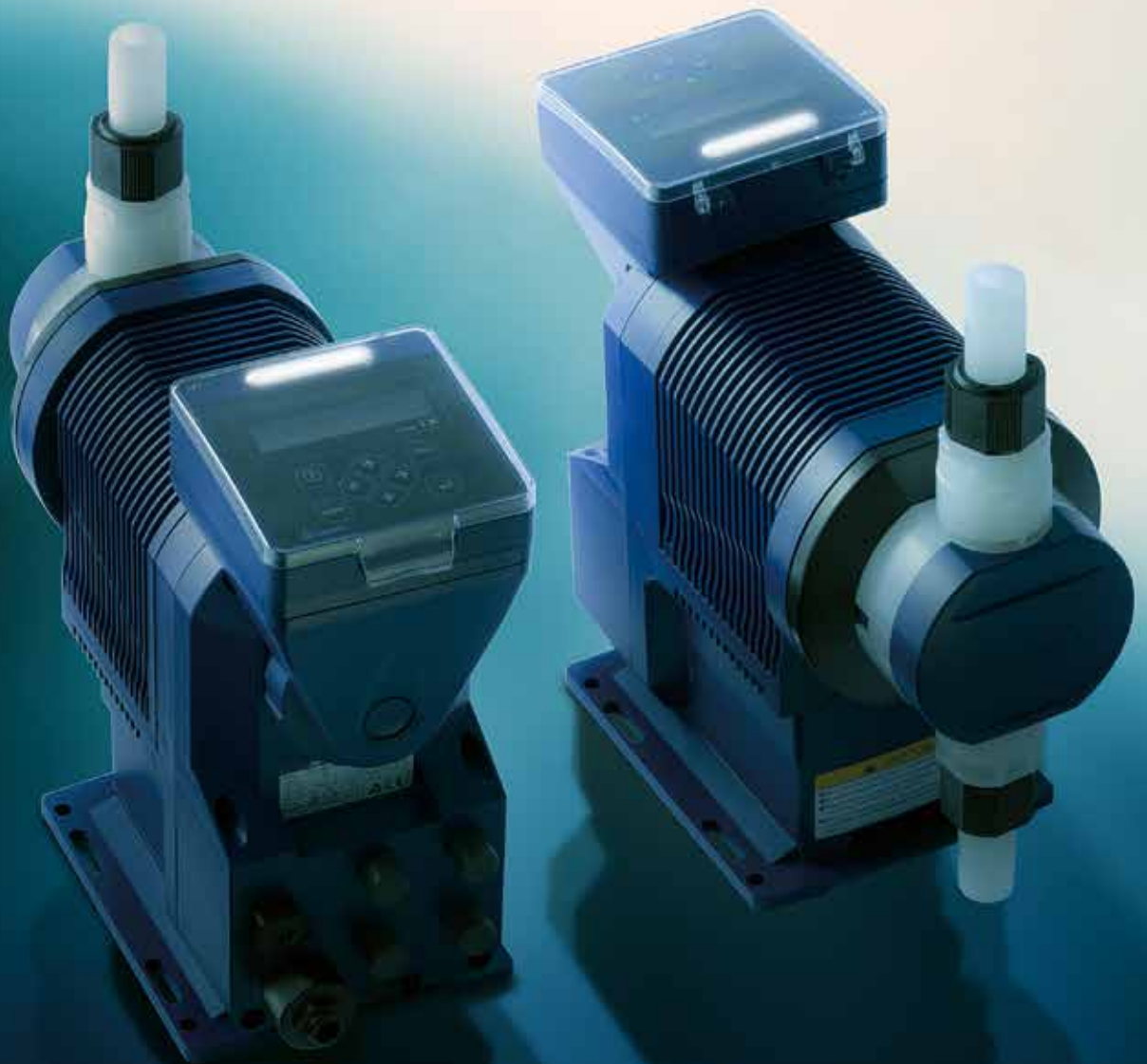

Unique Motor Design

The IX-B pumps use brushless DC (BLDC) motors to control the pump stroke speed. Many similar metering pumps use a step-per-motor based design, however the efficiency of the BLDC motor provides a higher power output in a smaller package and allows the IX-B pumps to achieve 45L/H discharge flowrates.

Degassing valve unit Design (Patent Pending)

One of the most advantageous features of the IWAKI IX Series Metering Pumps is the excellent degassing ability due to their proprietary valve unit design. The IX-B pumps retain this feature creating an entire pump line that will not gas lock and has no priming issues!

Flexible Installation (Patent Pending)

The IX-B Pumps have been designed to be installed into various locations. The control unit can easily be repositioned by customers on-site. The pump can also be relocated from base mounted to wall mounted without any extra parts required.

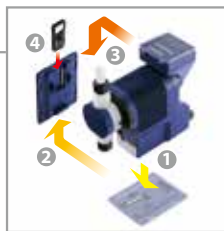

1. Remove the pump base.
2. Fix the pump base.
3. Hook the pump body.
4. Fix it with an adapter.



Upward 4 directions (every 90 degrees)

Two steps on both sides (every 35 degrees)

Installation example (with wall)

Improved Chemical Resistance

Liquid End materials of construction remains PVDF, a highly chemical resistance material, and a choice of elastomers (FKM or EPDM). New is a non-elastomer, solid PTFE diaphragm providing optimal resistance to chemical gas penetration and better all-around chemical resistance.

High Turndown Ratio and High Accuracy

The turndown ration of the IX-B series improves to 1000:1 via stroke rate control by the BLDC motor. The pumps are 1% repeatable across most of the control range. Minimum flow on the IX-B series is 0.0075L/H.

LED Status Bar

A large LED status bar provides simple visual indication of operating conditions at a glance. It is easily visible to see the pump status at a distance or in dark locations.



Flexible Connections

Tubing, Threaded, Flanged or Union (Made by George Fisher) connections are available as standard options providing easy installation for any application.

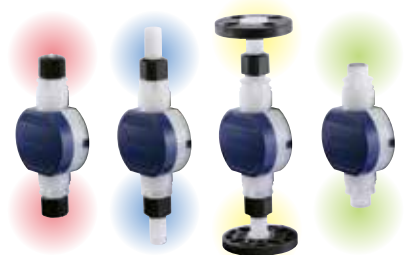

Safety design

Standard to all models is a diaphragm rupture detector, protecting users and the environment. Also, a detector for abnormal operation protects the pipework in case of an accidental high discharge pressure caused by clogging or improper operation. A drain hole also ensures safe operation even when the diaphragm is damaged.

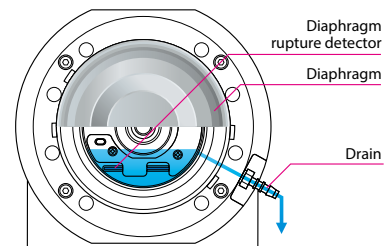

Note: In some cases it may not be able to detect sudden rises in pressure occurring in shutoff operation. If the piping or machinery in use has low pressure resistance, install a separate safety valve.



IX-B030

IX-B007

Construction and materials

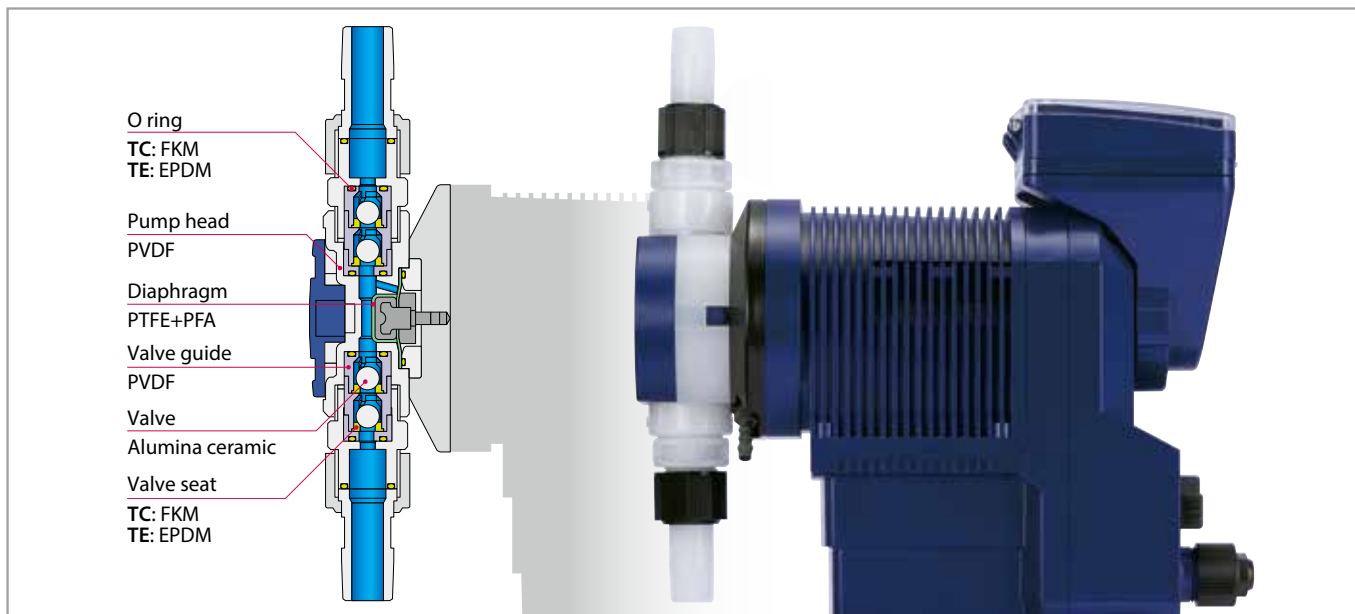

Pump identification

IX - B 007 TC R - E □□

- Drive unit**
B
- Pump size**
007 : 7.5L/H
015 : 15L/H
030 : 30L/H
045 : 45L/H
- Liquid-end material**
TC, TE
Please refer to above figure.
- Connection**
R : Thread(R)
N : Thread (NPT)
G : Thread (G)
F : Flange
T : Tube
- Special arrangement code**
No code : Standard models
□□ : Customized models
- Type of power code**
E : Europe
A : Australia
J : Asia
U : USA (115V)
U2 : USA (230V)

	Europe	Australia	Asia	USA
007/015	Ø4×Ø6	Ø6×Ø8	Ø4×Ø9, Ø4×Ø6	1/4"×3/8"
030/045	Ø9×Ø12	Ø9×Ø12	Ø8×Ø13, Ø9×Ø12	3/8"×1/2"

Performance chart

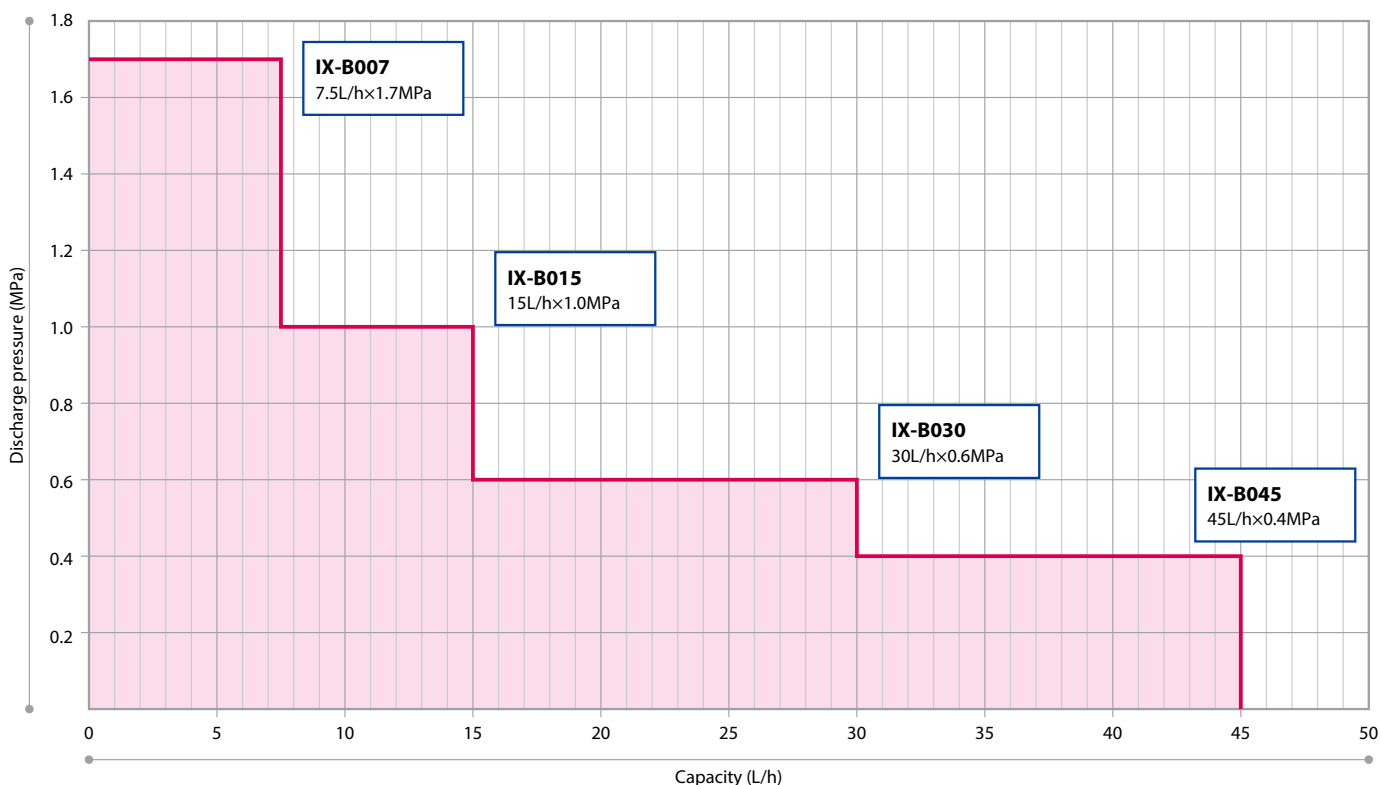

Specifications

Pump

Model	Capacity L/h	Max. pressure MPa	Power consumption W	Current A	Connection	Mass kg	
IX-B007 (TC, TE)	R	0.0075 - 7.5	1.7	17	0.4	R1/2	3.5
	N					1/2NPT	3.5
	G					G3/4	3.5
	T					Please refer to Pump identification.	3.5
	F					JIS 10K 15A, DIN PN10 DN15, ANSI 150Lb 1/2"	3.7
IX-B015 (TC, TE)	R	0.015 - 15	1.0	17	0.4	R1/2	3.5
	N					1/2NPT	3.5
	G					G3/4	3.5
	T					Please refer to Pump identification.	3.5
	F					JIS 10K 15A, DIN PN10 DN15, ANSI 150Lb 1/2"	3.7
IX-B030 (TC, TE)	R	0.03 - 30	0.6	19	0.5	R1/2	3.7
	N					1/2NPT	3.7
	G					G3/4	3.7
	T					Please refer to Pump identification.	3.7
	F					JIS 10K 15A, DIN PN10 DN15, ANSI 150Lb 1/2"	3.9
IX-B045 (TC, TE)	R	0.045 - 45	0.4	19	0.5	R1/2	3.7
	N					1/2NPT	3.7
	G					G3/4	3.7
	T					Please refer to Pump identification.	3.7
	F					JIS 10K 15A, DIN PN10 DN15, ANSI 150Lb 1/2"	3.9

Note 1: Use below the maximum allowable pressure of a connected tube.

· Liquid temperature range: 0 - 50 °C (TC, TE) (No viscosity change, Non freezing, No slurry.)

· Allowable voltage fluctuation: within ± 10% of the rated voltage

· Operating humidity range: 30 - 90%RH (Non condensing in the controller)

· The above is the value at rated voltage, ambient temperature and clear water.

· The pressure at which the abnormal pressure detection function operates is 1.3 to 2 times the maximum discharge pressure.

· Operating ambient temperature: 0 - 50 °C

· Flanges will be shared with the standards listed in the table.

Controller

Operation mode	MAN (Manual)	Use the UP (↑) and DOWN (↓) keys to set a flow rate.	
	EXT	Analog fixed operation	4-20, 0-20, 20-4, 20-0mA (Proportional to the discharge rate)
		Analog variable operation	Programmable 2-point setting (Input signal DC 0-20 mA, proportional to the discharge rate)
		Pulse control ^{Note1}	0.000625mL/PLS - 15.000000mL/PLS (IX-B007)
			0.001250mL/PLS - 30.000000mL/PLS (IX-B015)
			0.002500mL/PLS - 60.000000mL/PLS (IX-B030)
			0.003750mL/PLS - 90.000000mL/PLS (IX-B045)
		Batch control ^{Note1}	0.625mL/PLS - 15.000L/PLS (IX-B007)
1.250mL/PLS - 30.000L/PLS (IX-B015)			
2.500mL/PLS - 60.000L/PLS (IX-B030)			
3.750mL/PLS - 90.000L/PLS (IX-B045)			
Interval batch control ^{Note1}	Day: 0 - 9, Hour: 0 - 23, Minute: 1 - 59		
	0.625mL/PLS - 15.000L/PLS (IX-B007), 1.250mL/PLS - 30.000L/PLS (IX-B015) 2.500mL/PLS - 60.000L/PLS (IX-B030), 3.750mL/PLS - 90.000L/PLS (IX-B045)		
Profibus control ^{Note7}	Communication protocol: Profibus-DP-compliant international standard: EN50170 (IEC61158)		
Monitors	LCD	16 digits × 2 lines, backlight character LCD	
	LED	White: When the pump is stopped etc., Green: During pump operation etc., Orange: When entering Pre-Stop etc., Red: When alarm such as abnormal pressure detection etc.	
Operation	Keypads	(○)Start/Stop, MENU, ESC, (↵)Enter, (↑)Up, (↓)Down, (←)Left and (→)Right keys	
Control function	STOP	Operation stops with input contact ^{Note2}	
	PRIME	Max spm operation by pressing the (↑)UP and (↓)DOWN keys	
	Keylock	Password setting to lock and release operation keys	
	Interlock	Operation stops with input contact ^{Note2}	
	AUX	Pump operates at the set discharge rate with input contact.	
	Maximum discharge rate	Arbitrarily set the upper discharge limit in each operation mode.	
	Buffer memory function	Store the number of pulses entered in batch operation.	
Input	Analog input value display	Display the analog input value.	
	STOP/Pre-Stop	Non-voltage contact or open collector ^{Note3}	
	AUX	Non-voltage contact or open collector ^{Note3}	
	Interlock	Non-voltage contact or open collector ^{Note3}	
	Analogue	0 - 20mADC (Internal resistance is 200Ω.)	
Pulse	Non-voltage contact or open collector Max pulse frequency is 100Hz. (Pulse ON: 5 msec or more)		
Output	Alarm1 (OUT1)	Non-voltage contact (mechanical relay): AC 250 V, 3 A (resistive load) Each output item is selected by Enable/Disable. (Initial value: Leak Detection only Enable) Stop/Pre-Stop/Interlock/Leak Detection/Motor Overload/Batch Complete ^{Note4} /Drive Error	
	Alarm2 (OUT2)	Non-voltage contact (photo MOS relay): AC/DC 24 V, 0.1 A (resistive load) Each output item is selected by Enable/Disable. (Initial value: Interlock only Enable) Stop/Pre-Stop/Interlock/Leak Detection/Motor Overload/Batch Complete ^{Note4} /Drive Error/Volume Prop. PLS ^{Note5}	
	External power supply	DC12V 30mA or less	
	Current	DC 0-20 mA, Two-point setting (allowable load resistance: 300 Ω)	
Power voltage ^{Note6}		100-240VAC 50/60Hz	

Note1: The minimum settings for pulse operation, batch operation, and interval batch operation are the flow rates per stroke corrected by calibration.

Also, the change rate of the setting value per pulse is the flow rates per stroke corrected by calibration.

Note2: Pump operation or pump stop can be selected at contact input.

Note3: The maximum voltage and current applied to the contact are 12 V and 5 mA. If you use a contact such as a relay, the minimum applicable load must be 5 mA or less.

Note4: When Batch Complete (batch operation complete output) is set to Enable, the other functions will be set to Disable.

Note5: When Volume Prop. PLS output is set to Enable, the other functions will be set to Disable.

Note6: Do not apply voltage out of the specified range. Doing so may cause malfunction or failure. The allowable voltage supply range is 90-264VAC only.

Note7: When conducting Profibus bus operation, a separate Profibus Conversion BOX (option) is required.

Points to be observed in pump installation and piping

IX Series Hi-Techno pumps are positive-displacement, reciprocating pumps. Reciprocating pumps generate pulsation in the suction and discharge piping. Special consideration, (different from the ordinary centrifugal pumps), should be given to this point when planning the pump installation and piping.

• Prevention of pipe vibration

Discharge side inertial resistance $P_{id} < 0.1$ MPa
 • P_{id} : Inertial resistance on discharge side

Inertial resistance means the pulsed impact force generated by the flow just upon entering discharge stroke. It is a phenomenon particular to a reciprocating pump which is generated as a result of the sudden application of acceleration to the liquid in the discharge piping. The condition " $P_{id} < 0.1$ MPa is given above as an approximate standard. If P_{id} becomes 0.1MPa or higher, vibration on the pipe is generated. So measures should be taken to cope with the influence of vibration on the pump, too.

Measures

1. Install pulsation prevention device (air chamber).
2. Enlarge the diameter and shorten the length of the discharge piping.

• Prevention of overfeeding

Pump differential pressure > Inertial resistance P_i
 • The larger one of the suction side or the discharge side

Overfeeding means excessive flow of the liquid due to abnormal functioning of the check valve caused by pulsation of the liquid in the piping. Check carefully in case the differential pressure is low and in case the piping is too long even with the differential pressure value at 0.03 MPa.

Measures

1. Install air chamber.
2. Install back pressure valve

• Prevention of suction failure

$NPSH_a > NPSH_r$
 $NPSH_a = P_a - P_v \pm P_{hs} - P_{is} * MPa$
 *Or P_{fs} : whichever is the larger. (NPSH : Net positive suction head)

If NPSH_a is not sufficient, the pump may be damaged by the flow-break or cavitation generated under such conditions.

- **NPSH_a**: Absolute NPSH (MPa)
- **NPSH_r**: Required NPSH (value particular to the pump) (MPa)
- **P_a**: Absolute pressure onto the tank liquid surface (MPa)
- **P_v**: Liquid vapour pressure (MPa)
- **P_{hs}**: Pressure caused by the height of the suction side (MPa)
(Flooded suction : +, Negative suction : -)
- **P_{is}**: Inertial resistance on the suction side (MPa)
- **P_{fs}**: Piping resistance on the suction side (MPa)

See the table below for NPSH_r, inertia resistance(P_i) and applicable chambers.

⚠ Compressed air dissolves in solutions in a chamber. Supply air into the chamber periodically, or its performance may reduce. It takes longer time for air to be compressed enough to deliver liquid as a flow rate gets lower.

• Pump/Piping protection

Install a relief valve to protect the pump and piping from overpressure.

Performance

Model	Discharge line inertia resistance P_{id}		Suction line inertia resistance P_{is}		NPSH _r	Transportable viscosity		Priming lift	Applicable chamber Materials	
	L/h	MPa/1m	(%)	MPa/1m		Standard valve	Viscous valve		SUS	PVC
IX-B007	~7.50	8.3×10^{-4}	100	8.3×10^{-4}	0.07 MPaA	—	1000 mPa·s	1 m	0.5 L	1.0 L
	~5.60	2.9×10^{-4}	75	4.6×10^{-4}						
	~3.74	9.1×10^{-5}	50	2.1×10^{-4}						
	~1.87	1.7×10^{-5}	25	5.2×10^{-5}						
IX-B015	~15.0	1.6×10^{-3}	100	1.6×10^{-3}	0.07 MPaA	100 mPa·s	1000 mPa·s	2 m	0.5 L	1.0 L
	~11.2	5.8×10^{-4}	75	9.2×10^{-4}						
	~7.50	1.8×10^{-4}	50	4.1×10^{-4}						
	~3.74	3.3×10^{-5}	25	1.0×10^{-4}						
IX-B030	~30.0	2.7×10^{-3}	100	2.7×10^{-3}	0.06 MPaA	100 mPa·s	1000 mPa·s	2 m	0.5 L	1.0 L
	~22.4	9.7×10^{-4}	75	1.5×10^{-3}						
	~15.0	3.0×10^{-4}	50	6.8×10^{-4}						
	~7.50	5.5×10^{-5}	25	1.7×10^{-4}						
IX-B045	~45.0	4.1×10^{-3}	100	4.1×10^{-3}	0.06 MPaA	500 mPa·s	1000 mPa·s	2 m	0.5 L	1.0 L
	~33.6	1.5×10^{-3}	75	2.3×10^{-3}						
	~22.4	4.6×10^{-4}	50	1.0×10^{-3}						
	~11.2	8.2×10^{-5}	25	2.6×10^{-4}						
IX-B007Tube (Inner diameter Ø4)	~7.50	1.3×10^{-2}	100	1.3×10^{-2}	0.07 MPaA	—	1000 mPa·s	1 m	0.5 L	1.0 L
	~5.60	4.7×10^{-3}	75	7.5×10^{-3}						
	~3.74	1.5×10^{-3}	50	3.3×10^{-3}						
	~1.87	2.7×10^{-4}	25	8.4×10^{-4}						
IX-B015Tube (Inner diameter Ø4)	~15.0	2.6×10^{-2}	100	2.6×10^{-2}	0.07 MPaA	100 mPa·s	1000 mPa·s	2 m	0.5 L	1.0 L
	~11.2	9.4×10^{-3}	75	1.5×10^{-2}						
	~7.50	2.9×10^{-3}	50	6.6×10^{-3}						
	~3.74	5.3×10^{-4}	25	1.7×10^{-3}						
IX-B030Tube (Inner diameter Ø8)	~30.0	1.1×10^{-2}	100	1.1×10^{-2}	0.06 MPaA	100 mPa·s	1000 mPa·s	2 m	0.5 L	1.0 L
	~22.4	3.9×10^{-3}	75	6.2×10^{-3}						
	~15.0	1.2×10^{-3}	50	2.8×10^{-3}						
	~7.50	2.2×10^{-4}	25	6.9×10^{-4}						
IX-B045Tube (Inner diameter Ø8)	~45.0	1.6×10^{-2}	100	1.6×10^{-2}	0.06 MPaA	500 mPa·s	1000 mPa·s	2 m	0.5 L	1.0 L
	~33.6	5.9×10^{-3}	75	9.4×10^{-3}						
	~22.4	1.9×10^{-3}	50	4.2×10^{-3}						
	~11.2	3.3×10^{-4}	25	1.0×10^{-3}						

- P_i : Inertia resistance per meter (based on clean water, suction line I.D. should be equal to the pump suction connection as a minimum.)
- Calculate inertia resistance per meter using the following formula. $P_i = P_{id}$ (or P_{is}) \times Specific gravity \times Pipe length (m) \times (Pump I.D. \div Pipe I.D.)²(MPa)
- Suction speed is set to 100% as the default setting. Reduce speed when handling viscous or gaseous liquids to prevent the possibility of cavitation. Note the suction speed is used to control maximum discharge capacity. e.g.) If suction speed is set to 50%, maximum discharge capacity is correspondingly reduced to 50% (15 L/h: B030)
- Discharge capacity may be reduced from rated performance when pumping highly viscous liquids. Select a suitable pump size according to liquid viscosity. (About 20% lower)
- In addition, the viscous valve is spring-loaded and the material is stainless steel. (Special order correspondence)
- Applicable chamber: Capacities are based on Iwaki standard chamber sizes. Contact us for chamber materials.
- High accuracy: $\pm 1\%$ (It becomes ± 0.3 mL / h when it is set to 30 mL / h or less)
- Liquid temperature range: 0-50 °C. No viscosity change, Non freezing, No slurry

Dimensions (mm)

Connection: R/N (R Thread/NPT Thread)

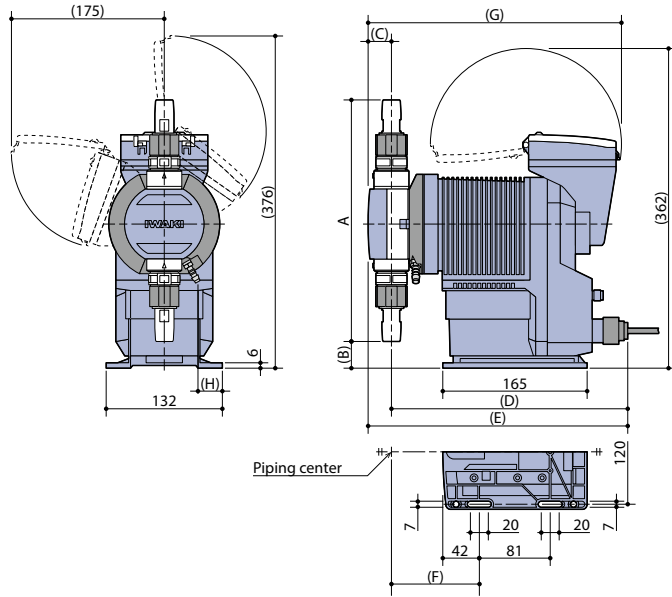

Connection: G (G Thread)

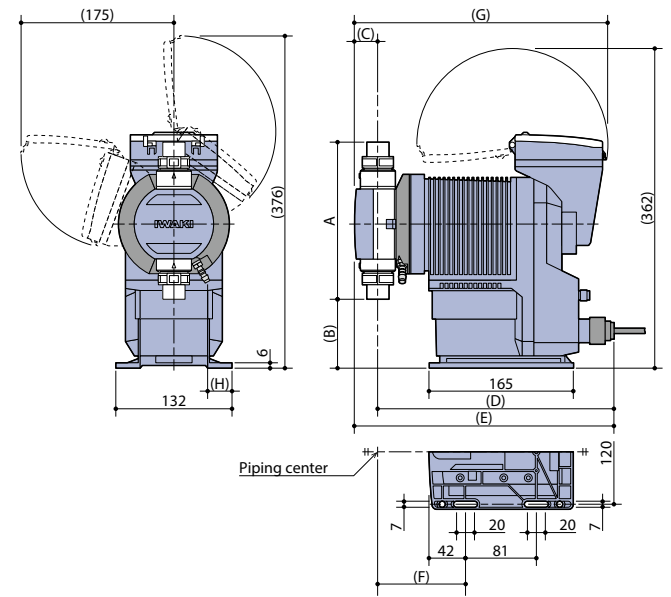

Connection: F (Flange)

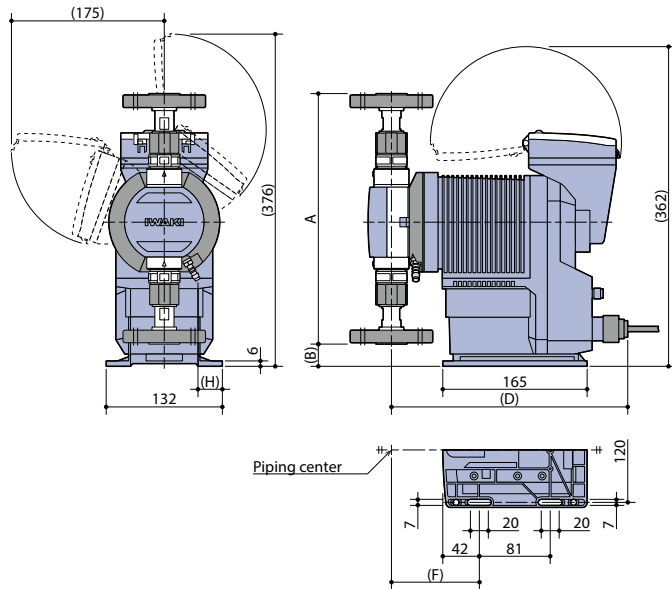

Connection: T (Tube)

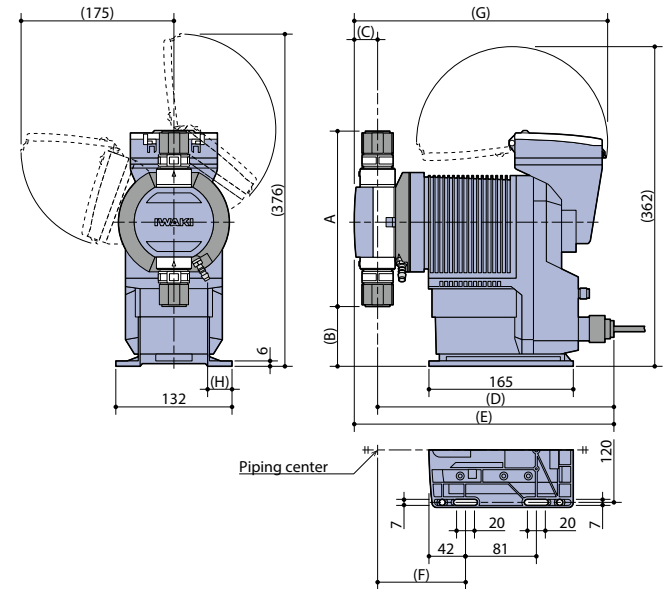

Model	Connection	A	B	C	D	E	F	G	H
IX-B007	R/N	240	45	24.3	267	291	94.5	284	29
	G	146	92						
	F	250	40						
	T	168	81						
IX-B015	R/N	249	41	24.3	267	291	94.5	284	29
	G	155	88						
	F	259	36						
	T	177	77						
IX-B030/045	R/N	273	30	26.4	270	296	97.5	289	28
	G	179	77						
	F	283	25						
	T	201	66						

Optional accessories



- DIN 5-pin connector cable** External control signal cable (5m) (External control signal input) Selection No. IX0018
- DIN 5-pin connector cable** STOP signal and AUX signal cable (5m) (STOP signal input) Selection No. IX0019
- DIN 4-pin connector cable** Output signal cable (5m) (Signal output) Selection No. IX0020
- Profibus converter** Profibus communication

IWAKI CO., LTD. 6-6 Kanda-Sudacho 2-chome Chiyoda-ku Tokyo 101-8558 Japan TEL : (81)3 3254 2935 FAX : 3 3252 8892

IWAKI has global net work.
Please find your distributor location at

www.iwakupumps.jp

European office	: IWAKI Europe GmbH	TEL: (49)2154 9254 0	FAX: 2154 9254 48	U.S.A	: IWAKI America Inc.	TEL: (1)508 429 1440	FAX: 508 429 1386
Germany	: IWAKI Europe GmbH	TEL: (49)2154 9254 50	FAX: 2154 9254 55	Argentina	: IWAKI America Inc. (Argentina Branch)	TEL: (54)11 4745 4116	
Holland	: IWAKI Europe GmbH (Netherlands Branch)	TEL: (31)74 2420011	FAX: (49)2154 925448	Brasil	: IWAKI Do Brasil Comercio De Bombas Hidraulicas LTDA.	TEL: (55)19 3244 5900	FAX: 19 3244 5900
Italy	: IWAKI Europe GmbH (Italy Branch)	TEL: (39)0444 371115	FAX: 0444 335350	Singapore	: IWAKI Singapore Pte Ltd.	TEL: (65)6316 2028	FAX: 6316 3221
Spain	: IWAKI Europe GmbH (Spain Branch)	TEL: (34)93 37 70 198	FAX: 93 47 40 991	Indonesia	: IWAKI Singapore (Indonesia Office)	TEL: (62)21 6906606	FAX: 21 6906612
Belgium	: IWAKI Belgium N.V.	TEL: (32)13 67 02 00	FAX: 13 67 20 30	Malaysia	: IWAKIm Sdn. Bhd.	TEL: (60)3 7803 8807	FAX: 3 7803 4800
Denmark	: IWAKI Nordic A/S	TEL: (45)48 24 2345	FAX: 48 24 2346	Australia	: IWAKI Pumps Australia Pty Ltd.	TEL: (61)2 9899 2411	FAX: 2 9899 2421
Finland	: IWAKI Suomi Oy	TEL: (358)9 2745810	FAX: 9 2742715	Hong Kong	: IWAKI Pumps Co., Ltd.	TEL: (852)2607 1168	FAX: 2607 1000
France	: IWAKI France S.A.	TEL: (33)1 69 63 33 70	FAX: 1 64 49 92 73	China	: GFTZ IWAKI Engineering & Trading Co., Ltd.	TEL: (86)20 84350603	FAX: 20 84359181
Norway	: IWAKI Norge AS	TEL: (47)23 38 49 00	FAX: 23 38 49 01		: IWAKI Pumps (Shanghai) Co., Ltd.	TEL: (86)21 6272 7502	FAX: 21 6272 6929
Sweden	: IWAKI Sverige AB	TEL: (46)8 511 72900	FAX: 8 511 72922	Korea	: IWAKI Korea Co., Ltd.	TEL: (82)2 2630 4800	FAX: 2 2630 4801
U.K.	: IWAKI Pumps (UK) Ltd.	TEL: (44)1743 231363	FAX: 1743 366507	Taiwan	: IWAKI Pumps Taiwan Co., Ltd.	TEL: (886)2 8227 6900	FAX: 2 8227 6818
			()Country codes	Thailand	: IWAKI (Thailand) Co., Ltd.	TEL: (66)2 322 2471	FAX: 2 322 2477



Caution for safety use:
Before use of pump, read instruction manual carefully to use the product correctly.

Actual pumps may differ from the photos. Specifications and dimensions are subject to change without prior notice. For further details please contact us.



Legal attention related to export.

Our products and/or parts of products fall in the category of goods contained in control list of international regime for export control. Please be reminded that export license could be required when products are exported due to export control regulations of countries.

The posting and copying from this catalogue without permission is not accepted firmly.