



**A new generation of advanced
metering pump technology!**

A new generation of advanced metering pump technology!

Hi-Techno Pump

IX

Highly precise control offers a solution for every chemical dosing application.

Iwaki's IX Series are digitally controlled direct-drive diaphragm pumps. Years of experience in high-end motor technology result in extremely accurate and energy efficient metering pumps with high resolution. The IX Series meet today's demand for automated chemical delivery in industries from water treatment to chemical process.



High turn down ratio



Viscous liquid transfer



Cavitation prevention



Automatic control



Energy savings
and Eco-friendly



Constant injection
with low impact



Degassing



Safety design



Precise chemical
dosing operation



IP65



Calibration



User friendly design



Efficient pump head design
is incorporated
with high compression



Compliant to
world standards



Operation history



Flexible Installation



High turn down ratio

Max. capacity range : 0.0075 - 300L/H, Max. pressure : 1.7MPa covers wide flow range.

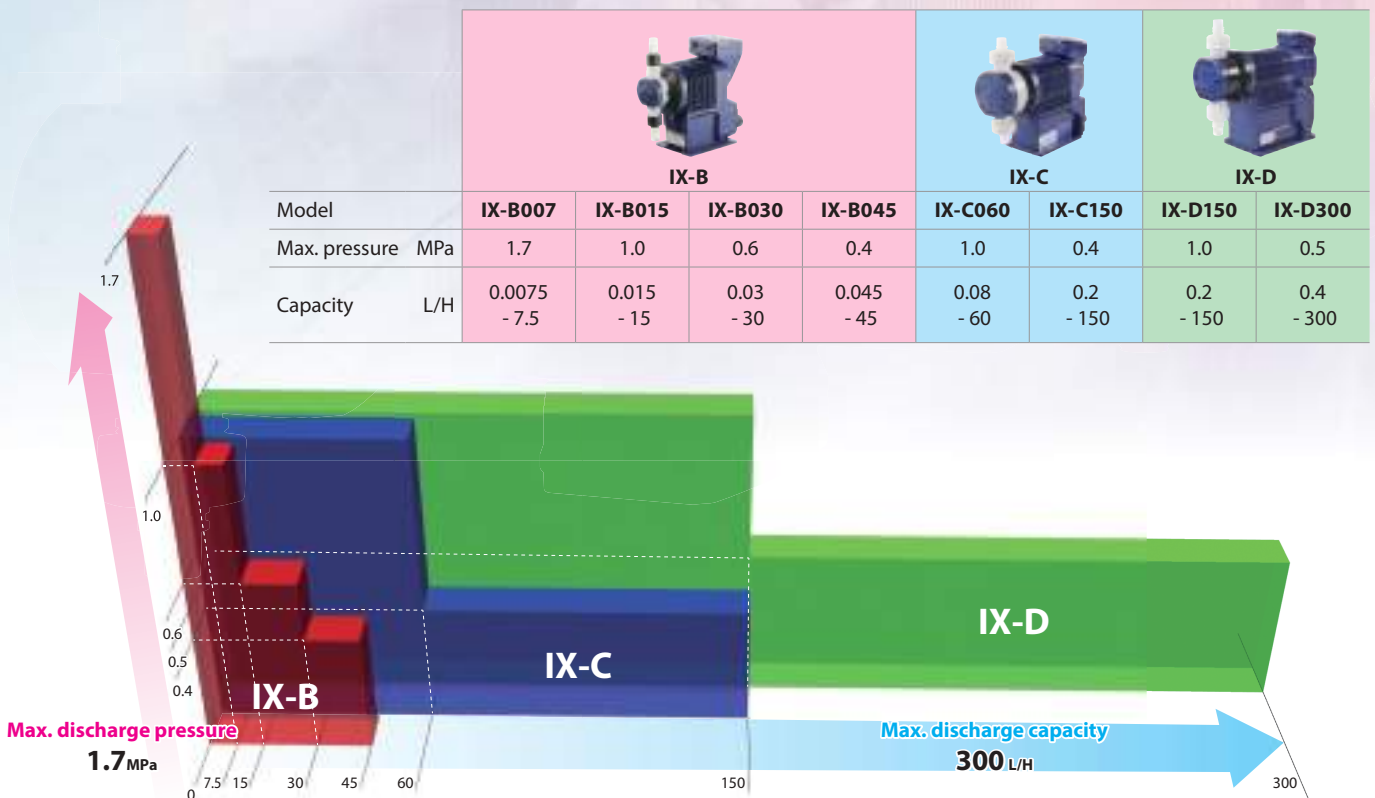

Energy savings and Eco-friendly

With the use of helical gears and spring assistance, power consumption is reduced by 70% compared to the standard spring back design.

*For IX-C type

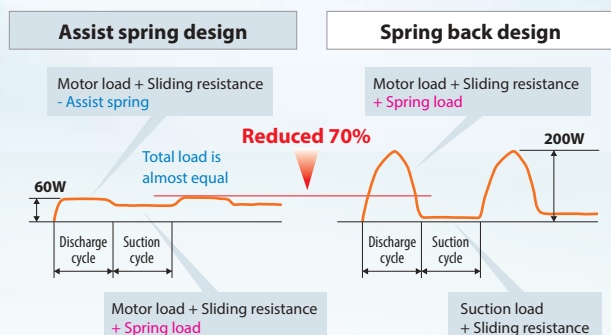

Precise chemical dosing operation

The valve design maintains precise dosing at any flow rate whilst the motor regulates discharge and suction speeds to achieve high accuracy (+/-1%) all with a cost effective design from a mechanically driven diaphragm pump.

*Some low flow rate areas are excluded.

Efficient pump head design is incorporated with high compression

Fast priming without air locks is achieved with a high compression ratio due to a fixed (maximum) stroke length.

Maximum suction lift:
2m With an open discharge line and dry valve condition.

Degassing ability :

IX-B007 : 1.0MPa	IX-B015 : 1.0MPa
IX-B030 : 0.6MPa	IX-B045 : 0.4MPa
IX-C060 : 1.0MPa	IX-C150 : 0.4MPa
IX-D150 : 1.0MPa	IX-D300 : 0.5MPa

With a standard tubing layout.

Viscous liquid transfer

Standard IX series is capable of pumping liquid viscosities of up to IX-B: 500mPa·s (IX-B045), IX-C: 1000mPa·s, IX-D: 300mPa·s. Contact us for higher viscosity applications.

*When transferring viscous liquid, the discharge rate may decrease. Custom orders are also available for viscosities of 1000 mPa · s and above. Please contact us for details.

IP65

Drive and control units are sealed separately to an IP65 enclosure.

Compliant to world standards

One of the IX features is multi-voltage operation (100-240VAC) compatible worldwide. Compliant to UL, CE standards.

Constant injection with low impact

Flow control via discharge speed adjustment (with a fixed suction speed) assures constant injection at any flow rate. This system also reduces impact (inertia force) and load to the discharge line.

Cavitation prevention

When pumping viscous liquids, suction stroke speed can be varied to avoid developing cavitation.

(Programmable suction speed: 75%, 50% or 25% of the normal speed)

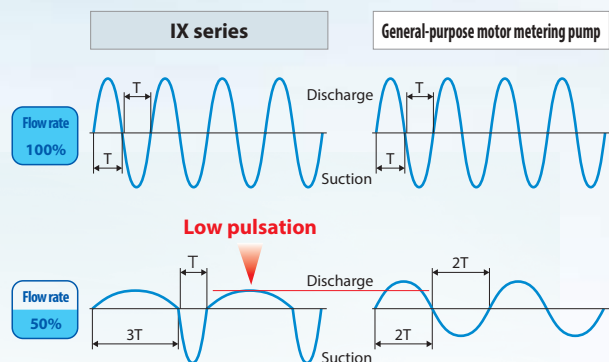

Degassing

Keypad operation or the contact signal (AUX) runs the pump at maximum spm in any mode for degassing.

Calibration

The pump is calibrated prior to shipment, however we recommend re-calibration when installed in your system due to pipe layout and liquid properties.

Operation history

Controller memory logs the total power connection time, operating time, number of strokes and number of power-up events.

Automatic control

The IX can run in analogue, pulse, batch or interval batch modes.

Analogue operation

The pump operates in response to an input, (4-20mA) from a controller.

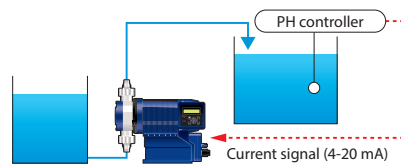

Pulse operation

When combined with a flow meter or contact head water meter, the IX pump gives a paced dose rate in proportion to the main flow rate.

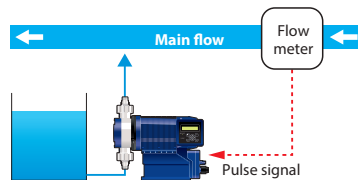

Interval batch operation

Timed operation is possible with simple pump programming via the keypad and is initiated with a pulse signal.

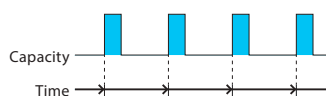

Safety design

Standard to all models is a diaphragm rupture detector, protecting users and the environment. Also, a detector for abnormal operation protects the pipework in case of an accidental high discharge pressure caused by clogging or improper operation. A drain hole also ensures safe operation even when the diaphragm is damaged.

*In some cases it may not be able to detect sudden rises in pressure occurring in shutoff operation. If the piping or machinery in use has low pressure resistance, install a separate safety valve.

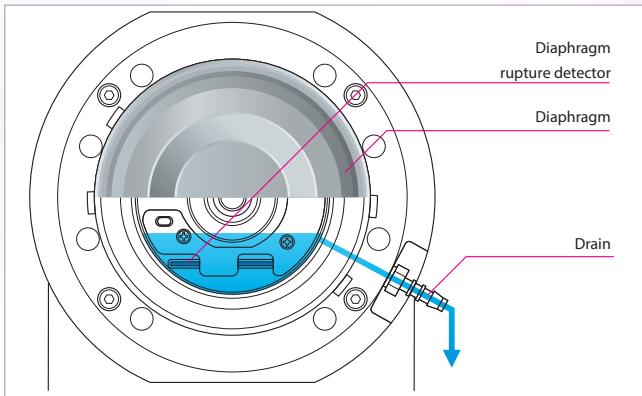

IX-B with excellent utility

Excellent corrosion resistance

PVDF with excellent corrosion resistance is used as standard for the wet end materials. The 100% fluororesin diaphragm also supports liquid transfer, which is easily permeable to gas.

LED Status Bar

A large LED status bar provides simple visual indication of operating conditions at a glance. It is easily visible to see the pump status at a distance or in dark locations.



Flexible Connections

Tubing, Threaded, Flanged or Union (Made by George Fisher) connections are available as standard options providing easy installation for any application.

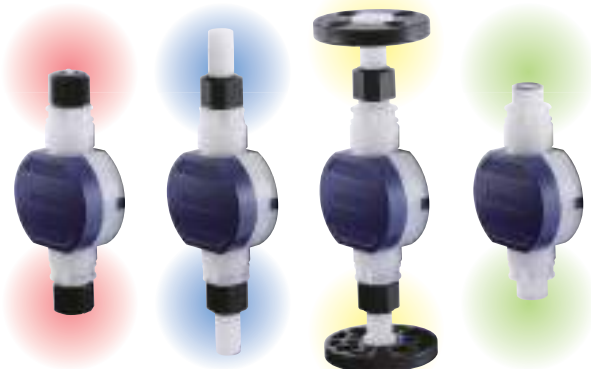

User friendly design

Operator mind design (IX-C/D)

The controller position can be selected from 6 mounting positions for operator convenience. Also, a character LCD with LED backlight and optimized keypad positions assist easy operation.

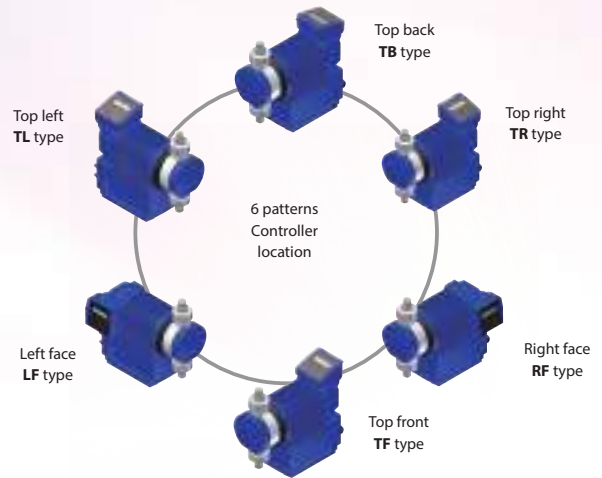

Flexible Installation Patent

(Patented country : Japan, USA, Germany, France, Denmark, China)

The IX-B Pumps have been designed to be installed into various locations. The control unit can easily be repositioned by customers on-site. The pump can also be relocated from base mounted to wall mounted without any extra parts required.

*IX-B-S6 cannot be wall-mounted.

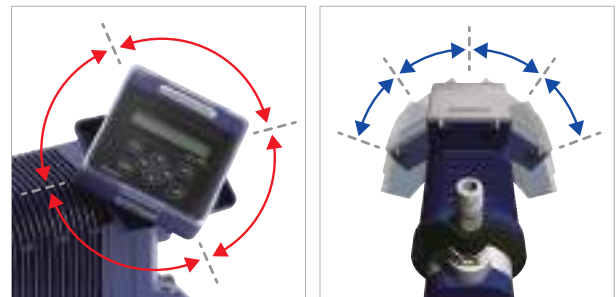

Upward 4 directions (every 90 degrees) Two steps on both sides (every 35 degrees)

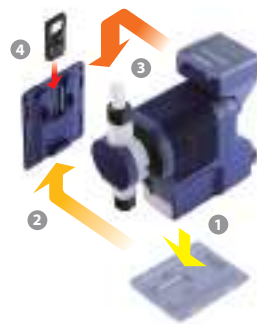

- 1 Remove the pump base.
- 2 Fix the pump base.
- 3 Hook the pump body.
- 4 Fix it with an adapter.



Installation example (with wall)

Construction and materials

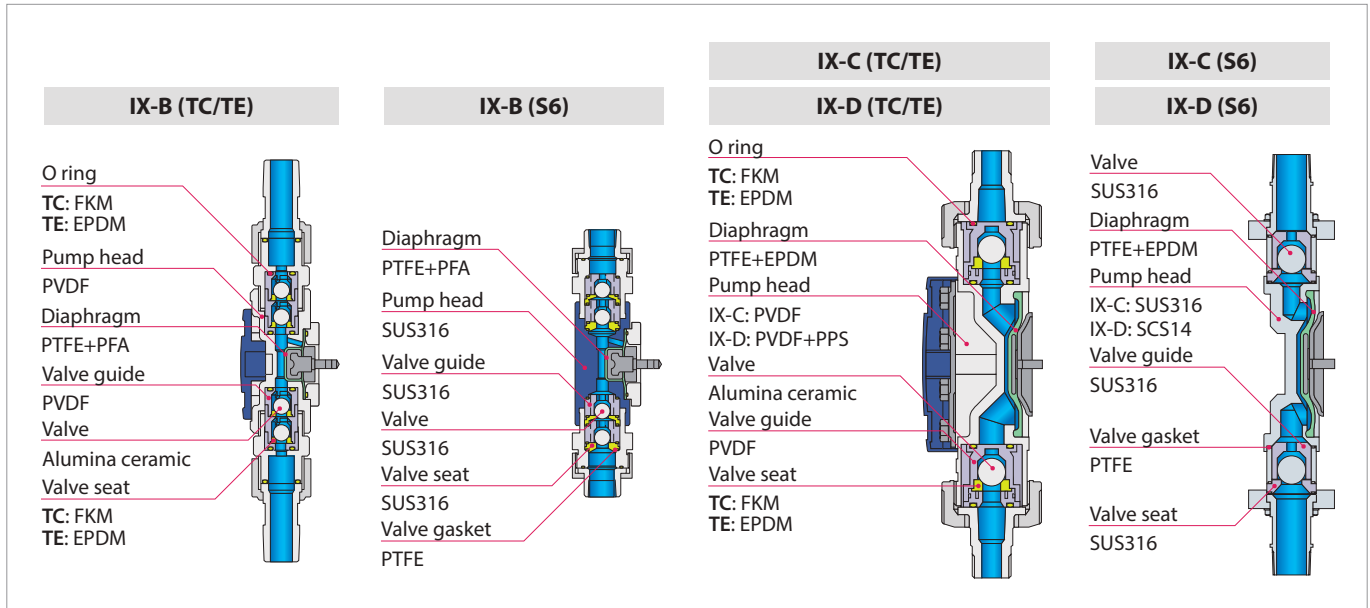

Note : PPS of the pump head and PFA/EPDM of the diaphragm is not wet end materials.

Identification

IX-B

IX - B 007 TC R - E □ □

- ① Drive unit
B
- ② Pump size
007 : 7.5L/H
015 : 15L/H
030 : 30L/H
045 : 45L/H
- ③ Liquid-end material
TC, TE
Please refer to above figure.
- ④ Connection
R : Thread (R)
N : Thread (NPT)
G : Thread (G)
F : Flange
T : Tube
- ⑤ Type of power code
E : Europe
A : Australia
J : Asia
U : USA (115V)
U2 : USA (230V)
- ⑥ Special arrangement code
No code : Standard models
□ □ : Customized models

	Europe	Australia	Asia	USA
007/015	Ø4×Ø6	Ø6×Ø8	Ø4×Ø9, Ø4×Ø6	1/4"×3/8"
030/045	Ø9×Ø12	Ø9×Ø12	Ø8×Ø13, Ø9×Ø12	3/8"×1/2"

IX-C

IX - C 150 TC R - TB 2 - E □

- ① Drive unit
C
- ② Pump size
060 : 60L/H
150 : 150L/H
- ③ Liquid-end material
TC, TE, S6
Please refer to above figure.
- ④ Connection
R : Thread (R)
N : Thread (NPT)
FJ : Flange (JIS)
FD : Flange (DIN)
FA : Flange (ANSI)
- ⑤ Controller position
TB : Top back
TF : Top front
TR : Top right
TL : Top left
RF : Right face
LF : Left face
- ⑥ Model code control number
1 : C060
2 : C150
- ⑦ Type of power code
E : Europe
J : Japan
U : USA (115V)
U2 : USA (230V)
- ⑧ Special arrangement code
No code : Standard models
S : Customized models

IX-D

IX - D 150 TC R - TB □ - E □

- ① Drive unit
D
- ② Pump size
150 : 150L/H
300 : 300L/H
- ③ Liquid-end material
TC, TE, S6
Please refer to above figure.
- ④ Connection
R : Thread (R)
N : Thread (NPT)
FJ : Flange (JIS)
FD : Flange (DIN)
FA : Flange (ANSI)
- ⑤ Controller position
TB : Top back
TF : Top front
TR : Top right
TL : Top left
RF : Right face
LF : Left face
- ⑥ Model code control number
No code : D150
No code : D300
- ⑦ Type of power code
E : Europe
J : Japan
U : USA (115V)
U2 : USA (230V)
- ⑧ Special arrangement code
No code : Standard models
S : Customized models

Optional accessories / example of piping

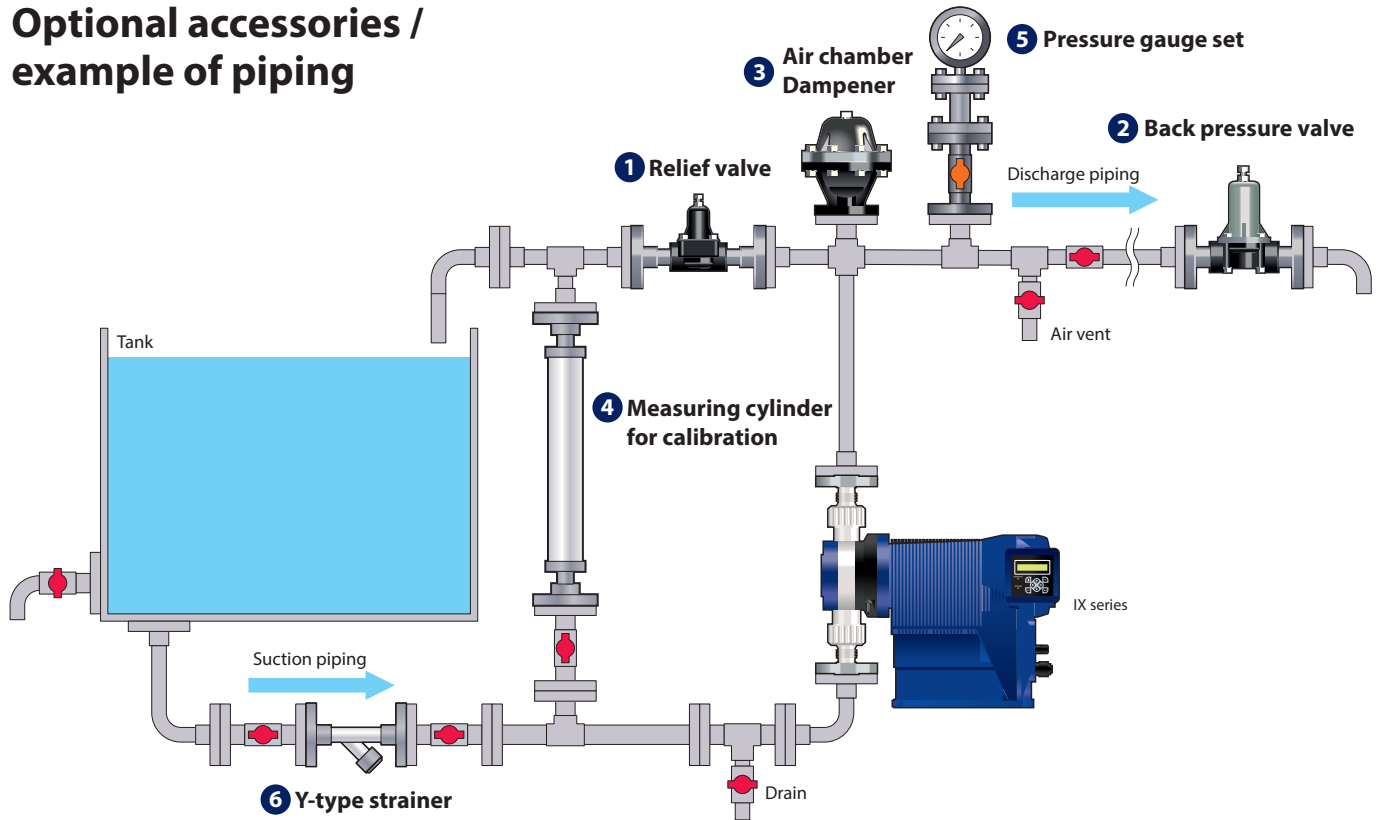

Check valve

Attached to the hose on the discharge side. It prevents overfeeding and backflow of the chemical solution and also prevents siphon.

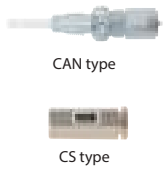

Model	Material		Set pressure MPa	Connection		Applicable pump	
	Body	Spring O-ring		IN	OUT		
CAN-1VC-M	PVC	FKM	0.17	±0.04	Hose connection Ø4×Ø9 ^{Note1} , Ø4×Ø6	Thread connection R3/8, R1/2	IX-B007/015
CAN-1VE-M		EPDM			Hose connection Ø8×Ø13 ^{Note1} , Ø9×Ø12	Thread connection R3/8, R1/2	
CAN-2VC-M		FKM	0.2	±0.04	Thread connection Rc1/4	Thread connection Rc1/4	IX-B007/015
CAN-2VE-M		EPDM			Thread connection Rc3/8	Thread connection Rc3/8	
CS-1S	SUS316	PTFE ^{Note2}	0.2	±0.04	Thread connection Rc1/4	Thread connection Rc1/4	IX-B007/015
CS-2S				±0.03	Thread connection Rc3/8	Thread connection Rc3/8	

Note1 : Applicable hose diameter can be changed. Refer to "Connection Diameter of the Multi-connection" on page 12 for details.

Note2 : The sealing of CS type is a gasket.

Relief valve Model RV

Positive displacement pumps keep operating even in a closed-discharge condition, resulting in piping breakage or pump failure from overpressurization without a relief valve. Always install a relief valve to prevent overpressure in the discharge line.



Model	Material			Max. capacity L/min (L/H)	Set pressure MPa	Connection JIS10K Flange	Applicable pump	Mass kg		
	Body	Diaphragm	O-ring							
RV-3T □-15	PVDF	PTFE	FKM EPDM	3.0 (180)	0.3 - 1.0	15A DIN PN10 DN15 ANSI 150LB 1/2" ^{Note2}	IX-B, C060	0.7		
RV-3T □-20						20A	IX-C150 IX-D150	0.8		
RV-3T □-MS						Hose connection Ø4×6, Ø4×9 Hose connection Ø8×13, Ø9×12	IX-B007/015 IX-B030/045	0.5		
RV-3T □-ML									Thread connection R1/2 Thread connection 1/2NPT Thread connection G3/4	IX-B
RV-3T □-R										
RV-3T □-N									25A	IX-D300
RV-3T □-G										
RV-3P-15	PVC	PTFE	3.0 (180)	0.3 - 1.0	15A	IX-B, C060	0.6			
RV-3P-20					20A	IX-C150 IX-D150				
RV-3P-25					25A	IX-D300		0.9		
RV-7TV-15	PVDF	PTFE	FKM EPDM FKM EPDM	7.5 (450)	0.3 - 0.8	15A	IX-B, C060	5		
RV-7TE-15						25A	IX-D300			
RV-7TV-25										
RV-7TE-25										
RV-2S6-15	SUS316 SCS14	PTFE	2.0 (120) 7.5 (450) 7.5 (450) 7.5 (450)	0.3 - 0.8 0.8 - 1.5 0.3 - 0.8 0.8 - 1.5 0.3 - 0.8 0.8 - 1.5	15A (JIS16K)	IX-B, C060	3.5			
RV-2S6B-15										
RV-7S6-20					20A (JIS16K)	IX-C150 IX-D150				
RV-7S6B-20										
RV-7S6-25					25A (JIS16K)	IX-D300				
RV-7S6B-25										

Note1 : When connecting a hose, use it at a hose normal pressure or less. When used with the IX-B007T (C/E) type pump, it can be installed in a pressure range of 0.3 to 1.7 MPa. However, the maximum flow rate is 0.125L/min (7.52L/H).

Note2 : The flange is a shared product that complies with the standards listed in the table.

Optional accessories

Back pressure valve

Model BV

Install a back pressure valve when discharge-line pressure is less than 0.03 MPa or less than suction-line pressure. Pump check valves may otherwise not operate correctly and overfeeding may result. Differential pressure between discharge and suction lines must be 0.03 MPa or more and also greater than the inertia resistance (Pid or Pis, whichever greater). Differential pressure (0.03 MPa or more) > Inertia resistance (Pid or Pis, whichever is greater)



PVDF type

2



PVC type

Model	Material			Max. capacity L/min (L/H)	Set pressure MPa	Connection JIS10K Flange	Applicable pump	Mass kg
	Body	Diaphragm	O-ring					
BV-3T□-15	PVDF	FKM EPDM	-	0.000125 (0.0075) - 3.0 (180)	0.1 - 0.8 ^{Note1}	15A DIN PN10 DN15 ANSI 150LB 1/2 ⁿ Note2	IX-B, C060	0.7
BV-3T□-20						20A	IX-C150 IX-D150	0.8
BV-3T□-MS						Hose connection Ø4×6, Ø4×9	IX-B007/015	0.5
BV-3T□-ML						Hose connection Ø8×13, Ø9×12	IX-B030/045	
BV-3T□-R						Thread connection R1/2	IX-B	
BV-3T□-N						Thread connection 1/2NPT		
BV-3T□-G						Thread connection G3/4		
BV-3P-15	PVC	PTFE	-	0.03 - 3.0 (1.8 - 180)	-	15A	IX-C060	0.6
BV-3P-20						20A	IX-C150 IX-D150	
BV-3NV-15	PVC	FKM	-	0.005 - 3.0 (0.3 - 180)	0.1 - 0.3	15A	IX-B, C060	0.6
BV-3NV-20						20A	IX-C150 IX-D150	
BV-3NE-15		EPDM				15A	IX-B, C060	0.6
BV-3NE-20						20A	IX-C150 IX-D150	
BV-7TV-15	PVDF	PTFE	FKM	0.2 - 7.5 (12 - 450)	0.05 - 0.8	15A	IX-B, C060	5
BV-7TE-15			EPDM					
BV-7V-20	PVC	-	PTFE	0.2 - 7.5 (12 - 450)	0.05 - 0.8	20A	IX-C150 IX-D150	3.5
BV-7F-C17							Thread connection Rc1/2	
BV-7F-C18	PVDF		Thread connection Rc3/4					
BV-7TV-25	PVDF	PTFE	FKM	0.2 - 7.5 (12 - 450)	0.05 - 0.8	25A	IX-D300	5
BV-7TE-25								
BV-2S6-15	SUS316 SCS14	-	PTFE	0.02 - 2.0 (1.2 - 120)	0.05 - 0.8	15A (JIS16K)	IX-B, C060	3.5
BV-2S6-C17						Thread connection Rc1/2	IX-B	
BV-2S6-C18						Thread connection Rc3/4		
BV-7S6-20	-	-	PTFE	2.0 - 7.5 (12 - 450)	0.1 - 0.8	20A (JIS16K)	IX-C150 IX-D150	6
BV-7S6-25						25A (JIS16K)	IX-D300	

Contact us for use at smaller flow rates than the above.

Note1: When connecting a hose, use it at a hose normal pressure or less.

Note2: The flange is a shared product that complies with the standards listed in the table.

Air chamber Model A

The air chamber reduces flow pulsation to prevent piping vibration and overfeeding. An air chamber designed for slurry transfer is also available.

Contact us for detail.



SUS type



PVC type

3

Model	Material		Capacity L	Max. pressure MPa	Connection JIS10K Flange	Applicable pump	Mass kg
	Body	O-ring					
A-1VV	PVC	FKM	1.0	0.5	15 - 25A (common)	IX-B, C060	2
A-1VE		EPDM					
A-2VV		FKM	2.0			IX-C150 IX-D150	
A-2VE		EPDM					
A-5VV		FKM	5.0			IX-D300	
A-5VE		EPDM					
A-05S6-10	SUS316	-	0.5	0.9	10A	IX-B	3
A-05S6-15					15A		
A-05S6-20					20A		
A-1S6-15			15A		IX-C060/150 IX-D150	5	
A-1S6-20			20A				
A-1S6-25			25A				
A-5S6-25			25A		IX-D300	12	
A-5S6-40			40A				

Contact us for other materials.

Dampener

Installed on the discharge side. Reduces pulsation and prevents piping vibration.

3



AQ-10



AQ-85

Model	Material		Capacity mL	Max. pressure MPa	Connection JIS10K Flange	Applicable pump
	Body	O-ring				
AQ-10TV	PVDF+PVC	FKM	164	0.05 - 0.5	Hose connection Ø4×Ø9, Ø4×Ø6	IX-B007/015
AQ-10TE		EPDM				
AQ-10TV-4		FKM				
AQ-10TE-4		EPDM				
AQ-85TV-15F	PVDF	FKM	1400	-	15A	IX-C060
AQ-85TE-15F		EPDM				
AQ-85TV-20F		FKM				
AQ-85TE-20F		EPDM			20A	IX-C150 IX-D150

The AQ-85 series is not in standard stock, so please contact us for the delivery date.

Strainer with a foot valve

Attached at the end of the suction hose. Prevents foreign matter from entering the pump chamber and water level fall in the suction hose when the pump is stopped.



Model	Material				Hose Connection	Applicable pump
	Body	Strainer	Valve	O-ring		
FSVN-1	PVC	Fluoro resin (ETFE)	Alumina ceramic	FKM	Ø4×Ø9	IX-B007/015
FSVN-2					Ø4×Ø6	
FSVN-4					Ø8×Ø13	IX-B030/045
FSVN-5					Ø9×Ø12	
FSEN-1	PVC	Fluoro resin (ETFE)	Hastelloy C276	EPDM	Ø4×Ø9	IX-B030/045
FSEN-2					Ø4×Ø6	
FSEN-4					Ø8×Ø13	
FSEN-5					Ø9×Ø12	
FSTCN-2	PVDF	Fluoro resin (ETFE)	Alumina ceramic	FKM	Ø4×Ø6	IX-B007/015
FSTCN-6					Ø10×Ø12	IX-B030/045

Mesh size : #20

Measuring cylinder for calibration

Used to calibrate the discharge rate of the pump. Installed on the suction side to measure the suction amount.



4

Model	Material	Capacity mL	Connection	Applicable pump
CC-PVC-500-FD	PVC	500	DIN15	IX-B
CC-PVC-1000-FD		1000		IX-C060
CC-PVC-2000-FD		2000	DIN20	IX-C/D150
CC-PVC-4000-FD		4000		IX-D300

Pressure gauge set

A convenient unit that combines a pressure gauge and a stop valve. Necessary to check the discharge pressure and control air supply to the air chamber. PVC type and SUS type are available.



5

Type	Line up	Material		Sealing material	Connection diameter	Max. pressure MPa
		Valve	Diaphragm			
PVC type	0.3MPa×Ø100×15A	PVC	PTFE	FKM (Ball valve FKM type) EPDM (Ball valve EPDM type) PTFE (Diaphragm valve type)	Flange connection 15A	0.3
	0.5MPa×Ø100×15A					0.5
	0.6MPa×Ø100×15A					0.6
	1.0MPa×Ø100×15A					1.0
SUS316 type	0.3MPa×Ø100×15A	SUS316	PTFE	PTFE	Flange connection 15A	0.3
	0.5MPa×Ø100×15A					0.5
	0.6MPa×Ø100×15A					0.6
	1.0MPa×Ø100×15A					1.0

Y-type strainer

Installed in the suction piping to prevent dirt and foreign matter from entering the pump chamber. PVC type and SUS type are available.



6

Type	Line up	Material		Connection diameter
		Body	Sealing material	
PVC type FKM	15A, FKM	PVC	FKM	15A
	25A, FKM			25A
PVC type EPDM	15A, EPDM		EPDM	15A
	25A, EPDM			25A
SUS type	15A	SUS	PTFE	15A
	20A			20A
	25A			25A

Mesh size : #40

DIN 5-pin connector cable

External control signal cable (5m)
(External control signal input)
Selection No. IX0018



DIN 5-pin connector cable

STOP signal and AUX signal cable (5m)
(STOP signal input)
Selection No. IX0019



DIN 4-pin connector cable

Output signal cable (5m)
(Signal output)
Selection No. IX0020



Profibus converter

Profibus communication



Specifications

Pumps

Model	Capacity L/hr	Max. pressure MPa	Max. viscosity mPa·s	Liquid temperature range °C	Connection	Power consumption W	Current A	Mass kg	
IX-B007 (TC/TE)	R	0.0075 - 7.5	1.7	___ ^{Note2, 3}	0 - 50	R1/2	17	0.4	3.5
	N					1/2 NPT			
	G					G3/4			
	T					Please refer to Pump identification.			
	F					JIS10K 15A, DIN PN10 DN15, ANSI 150LB 1/2" ^{Note5}			
IX-B007 S6	R	0.0075 - 7.5 ^{Note4}	1.7	1000 ^{Note2}	0 - 80	Rc3/8	17	0.4	4.5
	N					3/8 NPT			6.0
	F					FJ: JIS 10K 15A, FD: DIN PN10 DN15, FA: ANSI 150LB 1/2"			
IX-B015 (TC/TE)	R	0.015 - 15	1.0	100 ^{Note2, 3}	0 - 50	R1/2	17	0.4	3.5
	N					1/2 NPT			
	G					G3/4			
	T					Please refer to Pump identification.			
	F					JIS10K 15A, DIN PN10 DN15, ANSI 150LB 1/2" ^{Note5}			
IX-B015 S6	R	0.015 - 15	1.0	1000 ^{Note2}	0 - 80	Rc3/8	17	0.4	4.5
	N					3/8 NPT			6.0
	F					FJ: JIS 10K 15A, FD: DIN PN10 DN15, FA: ANSI 150LB 1/2"			
IX-B030 (TC/TE)	R	0.030 - 30	0.6	100 ^{Note2, 3}	0 - 50	R1/2	19	0.5	3.7
	N					1/2 NPT			
	G					G3/4			
	T					Please refer to Pump identification.			
	F					JIS10K 15A, DIN PN10 DN15, ANSI 150LB 1/2" ^{Note5}			
IX-B030 S6	R	0.030 - 30	0.6	1000 ^{Note2}	0 - 80	Rc3/8	19	0.5	5.0
	N					3/8 NPT			6.5
	F					FJ: JIS 10K 15A, FD: DIN PN10 DN15, FA: ANSI 150LB 1/2"			
IX-B045 (TC/TE)	R	0.045 - 45	0.4	500 ^{Note2, 3}	0 - 50	R1/2	19	0.5	3.7
	N					1/2 NPT			
	G					G3/4			
	T					Please refer to Pump identification.			
	F					JIS10K 15A, DIN PN10 DN15, ANSI 150LB 1/2" ^{Note5}			
IX-B045 S6	R	0.045 - 45	0.4	1000 ^{Note2}	0 - 80	Rc3/8	19	0.5	5.0
	N					3/8 NPT			6.5
	F					FJ: JIS 10K 15A, FD: DIN PN10 DN15, FA: ANSI 150LB 1/2"			
IX-C060 (TC/TE)	R	0.08 - 60 ^{Note4}	1.0	1000 ^{Note2}	0 - 50	R1/2	62	0.8	8
	N					1/2 NPT			9
	F					FJ: JIS 10K 15A, FD: DIN PN10 DN15, FA: ANSI 150LB 1/2"			
IX-C060 S6	R	0.08 - 60 ^{Note4}	1.0	1000 ^{Note2}	0 - 80	R1/2	62	0.8	10.5
	N					1/2 NPT			12
	F					FJ: JIS 10K 15A, FD: DIN PN10 DN15, FA: ANSI 150LB 1/2"			
IX-C150 (TC/TE)	R	0.2 - 150 ^{Note4}	0.4	1000 ^{Note2}	0 - 50	R3/4	62	0.8	9
	N					NPT 3/4			11
	F					FJ: JIS10K20A, FD: DIN PN16 DN20, FA: ANSI 150LB 3/4"			
IX-C150 S6	R	0.2 - 150 ^{Note4}	0.4	1000 ^{Note2}	0 - 80	R3/4	62	0.8	13
	N					NPT 3/4			
	F					FJ: JIS10K20A, FD: DIN PN10 DN20, FA: ANSI 150LB 3/4"			
IX-D150 (TC/TE)	R	0.2 - 150	1.0	300 ^{Note2, 3}	0 - 50	R3/4	110	1.3	14.5
	N					3/4 NPT			
	F					FJ: JIS10K20A, FD: DIN PN16 DN20, FA: ANSI 150LB 3/4"			
IX-D150 S6	R	0.2 - 150 ^{Note4}	1.0	300 ^{Note2, 3}	0 - 80	R3/4	110	1.3	15
	N					3/4 NPT			17
	F					FJ: JIS10K20A, FD: DIN PN10 DN20, FA: ANSI 150LB 3/4"			
IX-D300 (TC/TE)	R	0.4 - 300	0.5	300 ^{Note2, 3}	0 - 50	R1	110	1.3	15.5
	N					1 NPT			
	F					FJ: JIS10K 25A, FD: DIN PN16 DN25, FA: ANSI 150LB 1"			
IX-D300 S6	R	0.4 - 300 ^{Note4}	0.5	300 ^{Note2, 3}	0 - 80	R1	110	1.3	17
	N					1 NPT			19.5
	F					FJ: JIS10K 25A, FD: DIN PN10 DN25, FA: ANSI 150LB 1"			

Note1 : Use below the maximum allowable pressure of a connected tube.

Note3 : A dedicated valve is required when using with high-viscosity liquid.

Note2 : When transferring viscous liquid, the discharge rate may decrease. When selecting a pump, allow a margin for the discharge amount.

Note4 : For the IX-B, accuracy is not guaranteed at flows below 30 mL/h. For the IX-C060, accuracy is not guaranteed at flows below 0.4 L/h. For the IX-C150, accuracy is not guaranteed at flows below 1.0 L/h. For the IX-D150, accuracy is not guaranteed at flows below 1.5 L/h. For the IX-D300, accuracy is not guaranteed at flows below 3.0 L/h.

Note5 : Flanges will be shared with the standards listed in the table.

• The above is the value at rated voltage, ambient temperature and clear water. • The pressure at which the abnormal pressure detection function operates is 1.3 to 2 times the maximum discharge pressure.
 • No viscosity change, Non freezing, No slurry. • The max. discharge capacity is obtained in operation with clear water at ambient temperature and the max. discharge pressure. It gets higher as the pressure gets lower.
 • Operating humidity range: 30-90%RH (Non condensing in the controller) • Operating temperature range: 0-50 °C (Indoor use only) • Contact us for other plumbing connections.

Controllers

Operation mode	MAN (Manual)	Use the UP and DOWN keys to set a flow rate.		
	ANALOG	Analog fixed operation	4–20, 0–20, 20–4, 20–0 mA (Proportional to the discharge rate)	
		Analog variable operation	Programmable 2-point setting (Input signal DC 0–20 mA, proportional to the discharge rate)	
	Pulse control- Note1	IX-B	0.000625mL/PLS - 15.000000mL/PLS (IX-B007)	0.001250mL/PLS - 30.000000mL/PLS (IX-B015)
			0.002500mL/PLS - 60.000000mL/PLS (IX-B030)	0.003750mL/PLS - 90.000000mL/PLS (IX-B045)
			IX-C	0.00625mL/PLS - 120mL/PLS (IX-C060)
	Batch control- Note1	IX-B	0.625mL/PLS - 15.000L/PLS (IX-B007)	1.250mL/PLS - 30.000L/PLS (IX-C150)
			2.500mL/PLS - 60.000L/PLS (IX-B030)	3.750mL/PLS - 90.000L/PLS (IX-B045)
			IX-C	6.25mL/PLS - 120L/PLS (IX-C060)
	Interval batch control Note1	IX-B	0.625mL/PLS - 15.000L/PLS (IX-B007)	1.250mL/PLS - 30.000L/PLS (IX-B015)
2.500mL/PLS - 60.000L/PLS (IX-B030)			3.750mL/PLS - 90.000L/PLS (IX-B045)	
IX-C			6.25mL - 120L (IX-C060), 15.6mL - 300L/PLS (IX-C150)	
Profibus control Note2	IX-D	15.6mL - 300L (IX-D150), 31.2mL - 600L/PLS (IX-D300)		
		Day: 0 - 9, Hour: 0 - 23, Minute: 1 - 59		
Monitors	LCD	16 digits × 2 lines, backlight character LCD		
	LED	IX-B	White: When the pump is stopped etc., Green: During pump operation etc., Orange: When entering Pre-Stop etc., Red: When alarm such as abnormal pressure detection etc.	
LED		IX-C IX-D	OPERATE Lights in green color during pump operation. Lights in orange color when a Pre-Stop signal is input. Lights in red color when the pump has stopped or flashes when overload is detected. ALARM Red: Lights up when Alarm1 or Alarm2 is output	
	Operation	Keypads	(○)Start/Stop, MENU, ESC, (↵)Enter, (↑)Up, (↓)Down, (←)Left and (→)Right keys	
Control function	STOP	Operation stops with input contact ^{Note3}		
	PRIME	Max spm operation by pressing the (↑)UP and (↓)DOWN keys		
	Keylock	Password setting to lock and release operation keys		
	Interlock	Operation stops with input contact ^{Note3}		
	AUX	Pump operates at the set discharge rate with input contact.		
	Maximum discharge rate	Arbitrarily set the upper discharge limit in each operation mode.		
	Buffer memory function	Store the number of pulses entered in batch operation.		
Input	Analog input value display	Display the analog input value.		
	STOP/Pre-Stop	No-voltage contact or open collector ^{Note4}		
	AUX	No-voltage contact or open collector ^{Note4}		
	Interlock	No-voltage contact or open collector ^{Note4}		
	Analogue	0 - 20mADC (Internal resistance is 200ohm.)		
Output	Pulse	Non-voltage contact or open collector Max pulse frequency is 100Hz. (Pulse ON: 5 msec or more)		
	Alarm1 (OUT1)	Non-voltage contact (mechanical relay): AC 250 V, 3 A (resistive load) Each output item is selected by Enable/Disable. Batch complete ^{Note4} /STOP/Pre-Stop/Interlock/Leak Detection/Motor Overload/Drive Error		
	Alarm2 (OUT2)	Non-voltage contact (photo relay): AC/DC 24 V, 0.1 A (resistive load) Each output item is selected by Enable/Disable. Volume Prop. PLS ^{Note6} /Batch complete ^{Note5} /STOP/Pre-Stop/Interlock/Leak Detection/Motor Overload/Drive Error		
	External power supply	DC 12 V, 30 m A or less		
Power voltage ^{Note7}	Current	DC 0–20 mA, Two-point setting (allowable load resistance: 300 Ω)		
		100-240VAC 50/60Hz		

Note1 : The minimum settings for pulse operation, batch operation, and interval batch operation are the flow rates per stroke corrected by calibration.

Also, the change rate of the setting value per pulse is the flow rates per stroke corrected by calibration.

Note2 : A separate Profibus conversion BOX (option) is required to operate Profibus on IX.

Note3 : Switches to pump operation with input contact if default state is changed in the controller settings.

Note4 : The maximum voltage and current applied to the contact are 12 V and 5 mA. If you use a contact such as a relay, the minimum applicable load must be 5 mA or less.

Note5 : When Batch Complete (batch operation complete output) is set to Enable, the other functions will be set to Disable.

Note6 : When Volume Prop. PLS output is set to Enable, the other functions will be set to Disable.

Note7 : Do not apply voltage out of the specified range. Doing so may cause malfunction or failure. The allowable voltage supply range is 90-264VAC only.

Performance

Model	Discharge line inertia resistance Pid		Suction line inertia resistance Pis		NPSHr	Viscosity		Priming lift	Applicable chamber Materials	
	L/hr	MPa/1m	(%)	MPa/1m		Standard valve	Viscous valve		SUS	PVC
IX-B007	~7.50	8.3×10 ⁻⁴	100	8.3×10 ⁻⁴	0.07 MPaA	—	1000 mPa·s	1 m	0.5 L	1.0 L
	~5.60	2.9×10 ⁻⁴	75	4.6×10 ⁻⁴						
	~3.74	9.1×10 ⁻⁵	50	2.1×10 ⁻⁴						
	~1.87	1.7×10 ⁻⁵	25	5.2×10 ⁻⁵						
IX-B015	~15.0	1.6×10 ⁻³	100	1.6×10 ⁻³	0.07 MPaA	100 mPa·s	1000 mPa·s	2 m	0.5 L	1.0 L
	~11.2	5.8×10 ⁻⁴	75	9.2×10 ⁻⁴						
	~7.50	1.8×10 ⁻⁴	50	4.1×10 ⁻⁴						
	~3.74	3.3×10 ⁻⁵	25	1.0×10 ⁻⁴						
IX-B030	~30.0	2.7×10 ⁻³	100	2.7×10 ⁻³	0.06 MPaA	100 mPa·s	1000 mPa·s	2 m	0.5 L	1.0 L
	~22.4	9.7×10 ⁻⁴	75	1.5×10 ⁻³						
	~15.0	3.0×10 ⁻⁴	50	6.8×10 ⁻⁴						
	~7.50	5.5×10 ⁻⁵	25	1.7×10 ⁻⁴						
IX-B045	~45.0	4.1×10 ⁻³	100	4.1×10 ⁻³	0.06 MPaA	500 mPa·s	1000 mPa·s	2 m	0.5 L	1.0 L
	~33.6	1.5×10 ⁻³	75	2.3×10 ⁻³						
	~22.4	4.6×10 ⁻⁴	50	1.0×10 ⁻³						
	~11.2	8.2×10 ⁻⁵	25	2.6×10 ⁻⁴						
IX-B007T (Inner diameter Ø4)	~7.50	1.3×10 ⁻²	100	1.3×10 ⁻²	0.07 MPaA	—	1000 mPa·s	1 m	0.5 L	1.0 L
	~5.60	4.7×10 ⁻³	75	7.5×10 ⁻³						
	~3.74	1.5×10 ⁻³	50	3.3×10 ⁻³						
	~1.87	2.7×10 ⁻⁴	25	8.4×10 ⁻⁴						
IX-B015T (Inner diameter Ø4)	~15.0	2.6×10 ⁻²	100	2.6×10 ⁻²	0.07 MPaA	100 mPa·s	1000 mPa·s	2 m	0.5 L	1.0 L
	~11.2	9.4×10 ⁻³	75	1.5×10 ⁻²						
	~7.50	2.9×10 ⁻³	50	6.6×10 ⁻³						
	~3.74	5.3×10 ⁻⁴	25	1.7×10 ⁻³						
IX-B030T (Inner diameter Ø8)	~30.0	1.1×10 ⁻²	100	1.1×10 ⁻²	0.06 MPaA	100 mPa·s	1000 mPa·s	2 m	0.5 L	1.0 L
	~22.4	3.9×10 ⁻³	75	6.2×10 ⁻³						
	~15.0	1.2×10 ⁻³	50	2.8×10 ⁻³						
	~7.50	2.2×10 ⁻⁴	25	6.9×10 ⁻⁴						
IX-B045T (Inner diameter Ø8)	~45.0	1.6×10 ⁻²	100	1.6×10 ⁻²	0.06 MPaA	500 mPa·s	1000 mPa·s	2 m	0.5 L	1.0 L
	~33.6	5.9×10 ⁻³	75	9.4×10 ⁻³						
	~22.4	1.9×10 ⁻³	50	4.2×10 ⁻³						
	~11.2	3.3×10 ⁻⁴	25	1.0×10 ⁻³						
IX-C060	~60	4.4×10 ⁻³	100	4.4×10 ⁻³	0.08 MPaA	1000 mPa·s	2 m	1.5 L	2.0 L	
	~45	1.6×10 ⁻³	75	2.5×10 ⁻³						
	~30	4.9×10 ⁻⁴	50	1.1×10 ⁻³						
	~6	1.2×10 ⁻⁵	25	2.8×10 ⁻⁴						
IX-C150	~150	6.3×10 ⁻³	100	6.3×10 ⁻³	0.08 MPaA	1000 mPa·s	2 m	1.5 L	2.0 L	
	~113	2.3×10 ⁻³	75	3.6×10 ⁻³						
	~75	7.0×10 ⁻⁴	50	1.6×10 ⁻³						
	~15	1.8×10 ⁻⁵	25	4.0×10 ⁻⁴						
IX-D150	~150	6.3×10 ⁻³	100	6.3×10 ⁻³	0.08 MPaA	300 mPa·s	2 m	5.0 L	5.0 L	
	~113	2.3×10 ⁻³	75	3.6×10 ⁻³						
	~75	7.0×10 ⁻⁴	50	1.6×10 ⁻³						
	~15	1.8×10 ⁻⁵	25	4.0×10 ⁻⁴						
IX-D300	~300	7.2×10 ⁻³	100	7.2×10 ⁻³	0.08 MPaA	300 mPa·s	2 m	5.0 L	5.0 L	
	~225	4.1×10 ⁻³	75	4.1×10 ⁻³						
	~150	8.0×10 ⁻⁴	50	1.8×10 ⁻³						
	~30	2.0×10 ⁻⁵	25	4.5×10 ⁻⁴						

• Pi : Inertia resistance per meter (based on clean water, suction line I.D. should be equal to the pump suction connection as a minimum.)

Calculate inertia resistance per meter using the following formula.

$$Pi = Pid \text{ (or Pis)} \times \text{Specific gravity} \times \text{Pipe length (m)} \times (\text{Pump I.D.} \div \text{Pipe I.D.})^2 \text{ (MPa)}$$

• Suction speed is set to 100% as the default setting. Reduce speed when handling viscous or gaseous liquids to prevent the possibility of cavitation.

Note the suction speed is used to control maximum discharge capacity.

e.g.) If suction speed is set to 75%, maximum discharge capacity is correspondingly reduced to 75% (45L/h for IX-C060, 113 L/h for IX-C150).

• Discharge capacity may be reduced from rated performance when pumping highly viscous liquids. Select a suitable pump size according to liquid viscosity.

Contact us if handling liquid viscosities of over 1000 mPa·s.(IX-C) Contact us if handling liquid viscosities of over 300 mPa·s.(IX-D)

• Applicable chamber: Capacities are based on Iwaki standard chamber sizes. Contact us for chamber materials.

• High accuracy: ±1% (This accuracy may not be met at flows below 1.0 L/h for the IX-C150S6. For model IX-C060S6, accuracy may not be met at flows below 0.4 L/h)

• Liquid temperature range: 0-50 °C(TC/TE type), 0-80 °C(S6 type) No viscosity change, Non freezing, No slurry

Accurate calibration may not be possible with liquid temperatures over 60°C and discharge pressures over 0.8MPa. For optimum accuracy, calibration must be performed below these parameters.

Points to be observed in pump installation and piping

IX Series Hi-Techno pumps are positive-displacement, reciprocating pumps. Reciprocating pumps generate pulsation in the suction and discharge piping. Special consideration, (different from the ordinary centrifugal pumps), should be given to this point when planning the pump installation and piping.

• Prevention of pipe vibration

Discharge side inertial resistance $P_{id} < 0.1$ MPa
 • P_{id} : Inertial resistance on discharge side

Inertial resistance means the pulsated impact force generated by the flow just upon entering discharge stroke. It is a phenomenon particular to a reciprocating pump which is generated as a result of the sudden application of acceleration to the liquid in the discharge piping. The condition " $P_{id} < 0.1$ MPa is given above as an approximate standard. If P_{id} becomes 0.1MPa or higher, vibration on the pipe is generated. So measures should be taken to cope with the influence of vibration on the pump, too.

Measures
 1. Install pulsation prevention device (air chamber).
 2. Enlarge the diameter and shorten the length of the discharge piping.

• Prevention of overfeeding

Pump differential pressure $>$ Inertial resistance P_i
 • The larger one of the suction side or the discharge side

Overfeeding means excessive flow of the liquid due to abnormal functioning of the check valve caused by pulsation of the liquid in the piping. Check carefully in case the differential pressure is low and in case the piping is too long even with the differential pressure value at 0.03 MPa.

Measures
 1. Install air chamber.
 2. Install back pressure valve

• Prevention of suction failure

$NPSH_a > NPSH_r$
 $NPSH_a = P_a - P_v \pm P_{hs} - P_{is} * MPa$
 *Or P_{fs} : whichever is the larger. (NPSH : Net positive suction head)

If $NPSH_a$ is not sufficient, the pump may be damaged by the flow-break or cavitation generated under such conditions.

- **NPSH_a**: Absolute NPSH (MPa)
- **NPSH_r**: Required NPSH (value particular to the pump) (MPa)
- **P_a**: Absolute pressure onto the tank liquid surface (MPa)
- **P_v**: Liquid vapour pressure (MPa)
- **P_{hs}**: Pressure caused by the height of the suction side (MPa) (Flooded suction : +, Negative suction : -)
- **P_{is}**: Inertial resistance on the suction side (MPa)
- **P_{fs}**: Piping resistance on the suction side (MPa)

See the table below for NPSH_r, inertia resistance(P_i) and applicable chambers.

Compressed air dissolves in solutions in a chamber. Supply air into the chamber periodically, or its performance may reduce. It takes longer time for air to be compressed enough to deliver liquid as a flow rate gets lower.

• Pump/Piping protection

Install a relief valve to protect the pump and piping from overpressure.

Connection diameter of multi-joint

The applicable hose diameter can be switched by removing the fitting nut and recombining the hose stopper and hose adapter.

In addition, a hose stopper, hose adapter, and O-ring are available as a connection set. Please see the chart on the right for details.

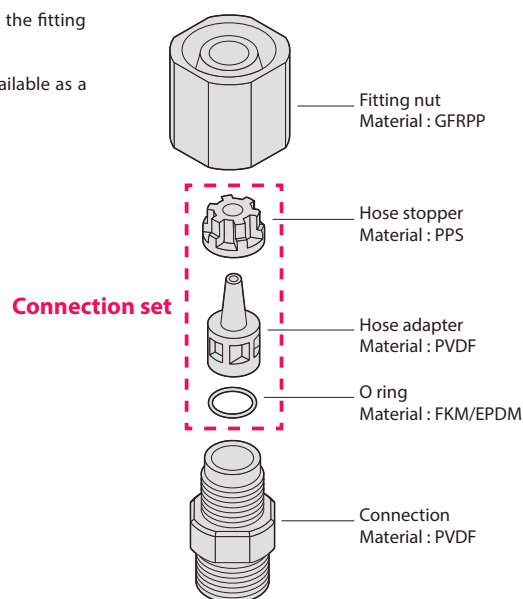

Dimension in mm

IX-B (TC/TE) Connection : R (Thread R)

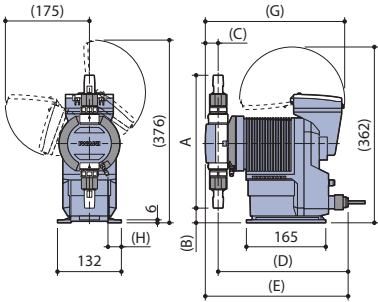

IX-B (TC/TE) Connection : G (Thread G)

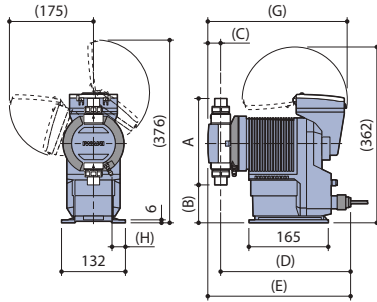

IX-B (TC/TE) Connection : F (Flange)

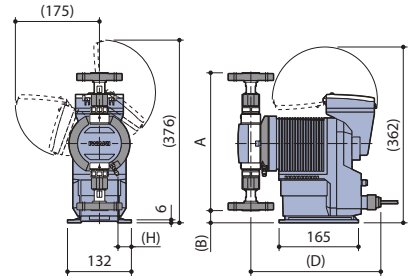

IX-B (TC/TE) Connection : T (Tube)

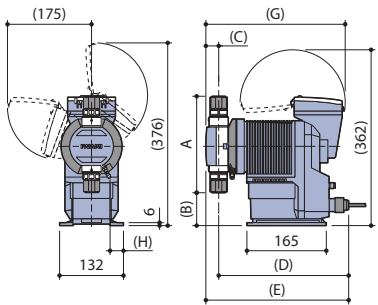

IX-B (S6) Connection : R (Thread R)

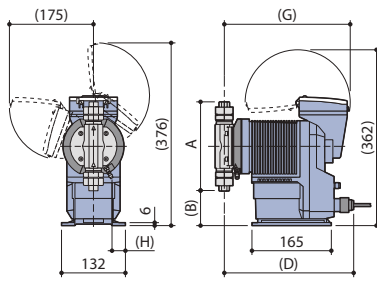

IX-B (S6) Connection : F (Flange)

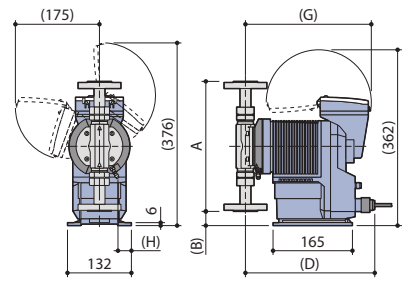

**IX-C Connection : Common to all types,
Controller position : RF (Right face)**

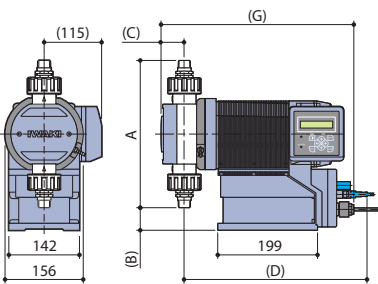

**IX-C (TC/TE) Connection : R (Thread R)
Controller position : TB (Top back)**

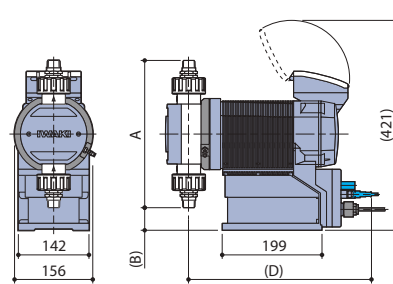

**IX-C (TC/TE) Connection : F (Flange)
Controller position : TB (Top back)**

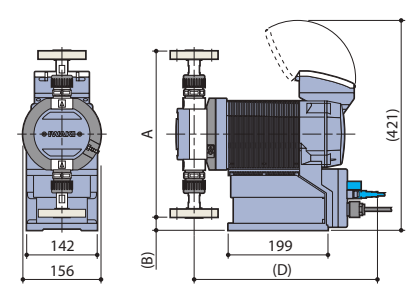

**IX-C (S6) Connection : R (Thread R)
Controller position : TB (Top back)**

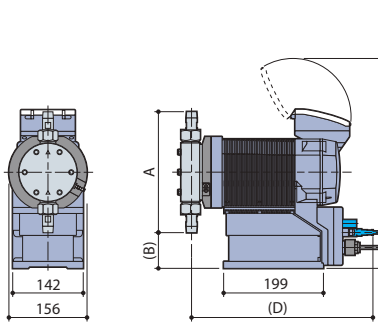

**IX-C (S6) Connection : F (Flange)
Controller position : TB (Top back)**

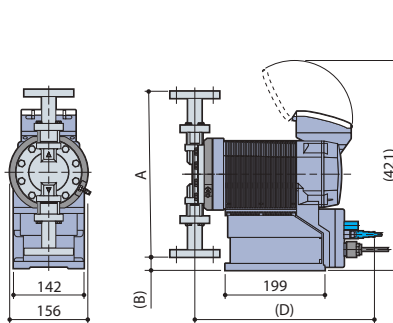

**IX-D Connection : Common to all types,
Controller position : RF (Right face)**

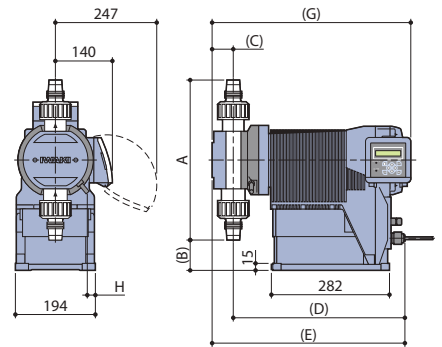

**IX-D (TC/TE) Connection : R (Thread R)
Controller position : TB (Top back)**

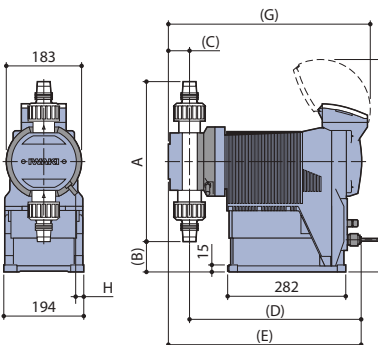

**IX-D (TC/TE) Connection : F (Flange)
Controller position : TB (Top back)**

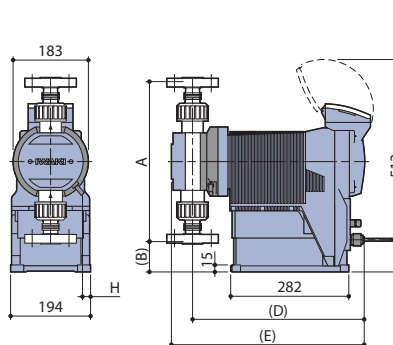

**IX-D (S6) Connection : R (Thread R)
Controller position : TB (Top back)**

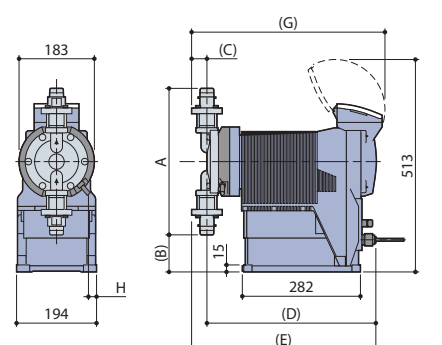

IWAKI CO., LTD. 6-6 Kanda-Sudacho 2-chome Chiyoda-ku Tokyo 101-8558 Japan TEL : (81)3 3254 2935 FAX : 3 3252 8892

IWAKI has global net work
Please find your distributor location at

www.iwakupumps.jp

European office : IWAKI Europe GmbH	TEL: (49)2154 9254 0	FAX: 2154 9254 48	U.S.A. : IWAKI America Inc.	TEL: (1)508 429 1440	FAX: 508 429 1386
Germany : IWAKI Europe GmbH	TEL: (49)2154 9254 50	FAX: 2154 9254 55	Argentina : IWAKI America Inc. (Argentina Branch)	TEL: (54)11 4745 4116	
Holland : IWAKI Europe GmbH (Netherlands Branch)	TEL: (31)74 2420011	FAX: (49)2154 925448	Brasil : IWAKI Do Brasil Comercio De Bombas Hidraulicas LTDA.	TEL: (55)19 3244 5900	FAX: 19 3244 5900
Italy : IWAKI Europe GmbH (Italy Branch)	TEL: (39)0444 371115	FAX: 0444 335350	Singapore : IWAKI Singapore Pte Ltd.	TEL: (65)6316 2028	FAX: 6316 3221
Spain : IWAKI Europe GmbH (Spain Branch)	TEL: (34)93 37 70 198	FAX: 93 47 40 991	Indonesia : IWAKI Singapore (Indonesia Office)	TEL: (62)21 6906606	FAX: 21 6906612
Belgium : IWAKI Belgium N.V.	TEL: (32)13 67 02 00	FAX: 13 67 20 30	Malaysia : IWAKIm Sdn. Bhd.	TEL: (60)3 7803 8807	FAX: 3 7803 4800
Denmark : IWAKI Nordic A/S	TEL: (45)48 24 2345		Australia : IWAKI Pumps Australia Pty Ltd.	TEL: (61)2 9899 2411	FAX: 2 9899 2421
Finland : IWAKI Suomi Oy	TEL: (358)9 2745810	FAX: 1 64 49 92 73	Hong Kong : IWAKI Pumps Co., Ltd.	TEL: (852)2607 1168	FAX: 2607 1000
France : IWAKI France S.A.	TEL: (33)1 69 63 33 70		China : GFTZ IWAKI Engineering & Trading Co., Ltd.	TEL: (86)20 84350603	FAX: 20 84359181
Norway : IWAKI Norge AS	TEL: (47)23 38 49 00		: IWAKI Pumps (Shanghai) Co., Ltd.	TEL: (86)21 6272 7502	FAX: 21 6272 6929
Sweden : IWAKI Sverige AB	TEL: (46)8 511 72900		Korea : IWAKI Korea Co., Ltd.	TEL: (82)2 2630 4800	FAX: 2 2630 4801
		()Country codes	Taiwan : IWAKI Pumps Taiwan Co., Ltd.	TEL: (886)2 8227 6900	FAX: 2 8227 6818
			Thailand : IWAKI (Thailand) Co., Ltd.	TEL: (66)2 322 2471	FAX: 2 322 2477



Caution for safety use:
Before use of pump, read instruction manual carefully to use the product correctly.

Actual pumps may differ from the photos. Specifications and dimensions are subject to change without prior notice. For further details please contact us.



Legal attention related to export.

Our products and/or parts of products fall in the category of goods contained in control list of international regime for export control. Please be reminded that export license could be required when products are exported due to export control regulations of countries.

The posting and copying from this catalogue without permission is not accepted firmly.